

THEORY MANUAL

THE AQUASIM PACKAGE THEORY USER MANUAL

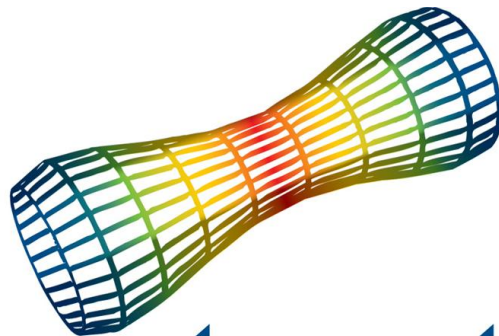

aquastructures

Safety through technology

Date of first issue: 10.09.2013	Project No.: 2049
Author: Are Johan Berstad	Verified: Ida Hystad
<p>Summary:</p> <p>The AquaSim Package Theory User Manual describes formulations and theory for the parameters used in AquaSim.</p>	

Title: The AquaSim Package Theory User Manual			Keywords: User Manual AquaSim FEM analysis
Doc. No.: TR-20000-2049-1			
Date, this version: 17.04.2026	Version: 2.22.0	Pages: 112	
			Distribution: Unlimited distribution

CONTENT

1	Introduction	8
1.1	Terminology	8
2	The aquasim package in brief.....	9
2.1	AquaEdit.....	9
2.2	AquaSim solver	9
2.3	AquaView	9
2.4	AquaTool.....	9
2.5	Other postprocessing tools.....	9
2.6	AquaSim system files	10
2.7	The <filename>key.txt.....	11
2.8	The <filename>val.txt	12
2.9	The <filename>conv.txt.....	12
3	Finite element analysis of nonlinear systems	13
3.1	Fundamentals of FE analysis	13
3.2	Static analysis	14
3.3	Dynamic analysis.....	16
4	Element properties, load and response: truss and beam	19
4.1	Truss and beam element	19
4.2	Local coordinate system	19
4.3	Stiffness matrix for truss element.....	20
4.4	Stiffness matrix for beam element.....	21
4.5	E-modulus.....	21
4.6	Shear modulus G (shear)	22
4.7	Cross sectional area	22
4.8	Area moment of inertia, I_y I_z	22
4.9	Area moment of inertia, torsion I_t	23
4.10	Volume.....	23
4.11	Weight and mass	23
4.12	Pretension, pre-strain	24
4.13	Mass radius	24
4.14	Rayleigh damping	25
4.15	Shear stress, shear area.....	25
4.16	Axial force	26
4.17	Shear force	26

4.18	Bending moment.....	26
4.19	Torsional moment.....	26
4.20	Wind load, response to wind.....	27
4.21	Longitudinal direction.....	27
4.21.1	Drag coefficient X.....	27
4.21.2	Added mass X.....	27
4.22	Morison load formulation: loads and coefficients.....	28
4.22.1	Added mass coefficient.....	28
4.22.2	Diameter for drag, drag area.....	29
4.22.3	Wave generated damping coefficient.....	29
4.22.4	Wave amplitude reduction and current reduction on Morison elements.....	30
4.22.5	Lift.....	30
4.22.6	Weight factor for slamming.....	31
4.22.7	Use visual cross section as slamming.....	31
4.22.8	Wave- and current induced viscous drift force.....	31
4.22.9	Wind load, response to wind.....	31
4.22.10	Include tangential Morison mass force.....	32
4.22.11	Advanced buoyancy.....	32
4.23	Hydrodynamic load formulation: loads and coefficients.....	34
4.23.1	Strip theory.....	34
4.23.2	Hydrostatic force.....	35
4.23.3	Hydrodynamic length coefficient.....	36
4.23.4	Neutral axis Z.....	37
4.23.5	Viscous roll damping.....	37
4.23.6	Wave amplitude reduction and current reduction on hydrodynamic elements	38
4.23.7	Horizontal components of hydrodynamic forces only.....	38
4.23.8	Forces and load direction.....	39
4.23.9	Wave drift.....	39
4.23.10	Wind load, response to wind.....	41
4.24	Point 3, node 3.....	43
4.25	Hinge.....	43
4.26	Winch.....	44
4.27	Linebreak.....	44
4.28	Valve.....	44

4.28.1	AquaSim parameters for valve	48
4.29	Catenary slope.....	50
5	Element properties, load and response: membrane	51
5.1	Local coordinate system	51
5.2	Structural properties of membrane type: Normal	51
5.2.1	Mask Type 1	52
5.2.2	Maskwidth Y and Maskwidth Z.....	54
5.2.3	Length of threads in local Y- and Z direction	55
5.2.4	Pretension Y and Z.....	55
5.3	Structural properties of membrane type: Normal with bending stiffness.....	58
5.4	Structural properties of 6-sided membrane	58
5.5	Structural properties of membrane type: Shell	59
5.6	Load formulation membrane: Regular net.....	60
5.7	Load formulation membrane: Lice skirt.....	60
5.8	Load formulation: Closed compartment.....	60
5.9	Load formulation: Surface tarpaulin.....	61
5.10	Load formulation membrane: Morison free plate	61
5.11	Current reduction on membrane	62
5.12	Wave amplitude reduction on membrane	63
5.13	Fouling/ growth on membrane	63
5.14	Mass density and weight.....	63
5.15	Pretension for membrane	63
5.16	Volume.....	64
5.17	Net in air	64
5.18	Rayleigh damping	64
5.19	No compression forces.....	64
6	Node properties	65
6.1	Degree of freedom, DOF	65
6.2	Local coordinate system	65
6.3	Pointload.....	65
6.4	Impulse load	67
6.5	Prescribed	67
6.6	Spring.....	67
6.7	RAO.....	69
6.7.1	RAO on nodes	69

6.7.2	RAO on Pointload	70
6.7.3	RAO on Spring	71
6.8	Roller	72
7	Element properties: Node2Node	73
7.1	Node to node spring	73
7.2	Node to node damping	73
8	Nonlinear material behavior	74
9	Loads	74
9.1	Static load	74
9.2	Environmental loads	75
9.2.1	Waves	75
9.2.2	Regular wind	81
9.2.3	Irregular wind and wind spectra	81
9.2.4	Current	81
10	Properties for timedomain simulation	82
10.1	Incrementation of static loads	82
10.2	Preincrement, number of initial steps	82
10.3	Max iterations per step	82
10.4	Incrementation of dynamic loads	83
10.5	Num total steps for waves	83
10.6	Num steps for one wave	83
10.7	Convergence	83
10.7.1	Convergence criteria	83
10.8	Importance of time step size, response to snap loads	84
10.9	Current reduction type	89
10.10	Infinite depth	89
10.11	Cresting Wave Factor	89
10.12	Depth (wave profile)	90
10.13	Bottom contact	90
10.14	Bottom depth	90
10.15	Bottom parameter	90
10.16	Bottom friction	90
10.17	Dynamic vertical friction	90
10.18	Dynamic horizontal friction	91
10.19	Water volume correction	91

10.19.1	None.....	91
10.19.2	With slamming	91
10.20	Water entry and exit.....	91
10.20.1	Water entry	92
10.20.2	Water exit	99
10.21	Buckling analysis	99
10.22	Beam buckling	99
10.23	Explicit eigenperiod analysis	101
11	Component Contact.....	102
11.1	Component contact table.....	103
11.1.1	First part and Second part.....	103
11.1.2	Distance / Radius	103
11.1.3	Stiffness	103
11.1.4	Damping stiffness	103
11.1.5	Dynamic friction damping.....	104
11.1.6	Static stiffness friction coefficient.....	104
11.1.7	Max initial distance	104
12	References	105
13	Appendix A: Validation of the AquaSim slamming formulation	110
13.1	Case 1: Beam through water at constant velocity	110
13.2	Case 2: Fixed beam in waves	111

1 INTRODUCTION

AquaSim is an analysis tool developed by Aquastructures AS. It utilizes the Finite Element Method (FEM) for calculation and simulation of structural response. The software is well suited for slender, lightweight- and large volume structures, flexible configurations and coupled systems exposed to environmental loads such as:

- waves
- currents
- wind
- impulse loads
- operational conditions
- resonance

This manual describes the AquaSim analysis tool and the theory for the main use. For more detailed understanding, this report should be complemented with papers and technical reports regarding the specific area of concern.

1.1 Terminology

Throughout this manual, certain terms appear. These are defined as:

Term	Definition
Node	Point in 3D space that describes end points of element.
Element	Object between two nodes (straight element) or four nodes (membrane element). The simulation process will treat each element as a discrete object.
Beam	A beam is a structural element that is capable of withstanding load primarily by resisting torsion and axial loads.
Membrane	Structural element used for nets and tarps.
Truss	Structural element where forces in the members are either tensile or compressive forces. I.e. ropes.
Component	A group of elements which is defined by the same material data. Components are defined either as beam, truss, membrane or node2node.
E-modulus	Young's modulus, or the modulus of elasticity (force per unit area).
Incident wave	Wave(s) propagating towards an object.
Conservation of momentum	Newton's second law.
Cross-flow principle	The fluid velocity relative to an object is split into its components normal and parallel to the object's axis.
Dummy	A variable, or categorical effect, that is not taken into account in the AquaSim analysis.

2 THE AQUASIM PACKAGE IN BRIEF

The software consists of a preprocessor (AquaEdit), a solver, and postprocessors (AquaView, AquaTool, and other tools). For practical use of these, reference is made to their respective user manuals.

AquaSim handles global analysis and interactions of forces transmitted between stiff and flexible components. Displacements, accelerations, velocities, and deformations in the structure is calculated. The results are presented in the form of e.g. local section forces, stresses, and stress ranges in each system component, applicable for further local analysis and fatigue assessments. AquaSim accounts for hydro-elasticity, to handle the coupled dynamics between the external loads and the construction. This means the program handles calculation of response in structures or systems where the loads acting on the structure depends on structural deformations.

2.1 AquaEdit

In the preprocessor AquaEdit, a geometrical model is established through a graphical interface. Structural and hydrodynamical properties are defined and added to the model.

2.2 AquaSim solver

The prepared analysis model in AquaEdit, is computed by the AquaSim solver. The solver calculates forces and moments from the given geometry, properties, and environmental loads. The solver is based on time domain simulation of structural response in coupled systems.

2.3 AquaView

The postprocessor AquaView, presents results from the solver graphically in 3D.

2.4 AquaTool

The postprocessor AquaTool, presents results from the solver in tables and diagrams.

2.5 Other postprocessing tools

Other postprocessing tools are also included. These are suitable for handling large result files, and are called PostProcFilter (ppfilter), PostProcReduce (ppreduce) and Surface Extractor (ppsurface).

2.6 AquaSim system files

The AquaSim package is typically installed at C:\Program Files\Aquastructures\AquaSim. The solver can either be started through AquaEdit, or it can be run in batch. Upon start and finish of an analysis, several files are generated. These are described in Table 1.

Table 1 Files generated from AquaEdit and the solver. Assumed a base filename called 'p1'.

File	File name	Description
Batch file	p1.bat	Batch file. ASCII format. Double click for running analysis. The bat file consists of a set of commands easily editable.
XML file	p1.xml	XML file. ASCII format. This file holds graphic information and other key data.
Result file	p101.avs	Result file generated by the solver during execution of analysis. This file holds results in ASCII format.
Result file	p101.avz	Result file generated by the solver after completion of analysis. This file is a compressed version of the avs file.
Input file	p101.txt	Input file in ASCII format. Holds information about the model and analysis setup. Generated from AquaEdit upon export.
XML file	p101.xml	XML file. ASCII format. This file holds graphic and other key data for activated components from AquaEdit. This is the file used for the analysis of the p101.txt input file.
	p101-all.xml	XML file. ASCII format. This file is similar as for .xml, but includes graphics and key data for all components from AquaEdit – activated and deactivated components.
Result convergence file	p101conv.txt	Holds information about the analysis status concerning number of iterations used to achieve convergence for the analysis of the p101.txt input file.
Result file key data	p101key.txt	Contains a set of key data of the analysis model. This may be used for self-validation of input. Also holds information about license and user key data.
Result file	p101PFAT.avs	Result file generated by the solver upon completion of analysis. This file holds key data and max result values of the p101.avs file. ASCII format.
Result file	p101PFAT.avz	Result file generated by the solver upon completion of analysis. This file is a compressed version of the avs file.
Result file validation data	p101val.txt	This file holds a set of key data from the analysis. This may be used for self-validation of input. Some basic data is given in the p101key.txt file, the p101val.txt contains additional key data.
Result file	p101hydro.txt	Result file containing key data of hydrostatic data of the analysis model. ASCII format.
Result ID file	p101-elements.txt	Holds information about elements given custom ID-names in AquaEdit.
Result ID file	p101-nodes.txt	Holds information about nodes given custom ID-names in AquaEdit.

2.7 The <filename>key.txt

The output file, <filename>key.txt contain information about license, weight and buoyancy data for each component in the analysis model. An excerpt of this file is shown in Figure 1, presenting weight and buoyancy data for a range of components.

In water weight, In air weight, In water buoyancy, Total length (twines if net)

	Number ,	N ,	N ,	N ,	m
Component	1	-0.8336E+06	0.1278E+07	0.2112E+07	0.1278E+04
Component	2	0.6293E+06	0.2244E+07	0.1615E+07	0.1278E+04
Component	3	0.0000E+00	0.1228E+06	0.1228E+06	0.3525E+07
Component	4	0.0000E+00	0.1085E+06	0.1085E+06	0.3437E+07
Component	5	0.3401E+04	0.1478E+06	0.1444E+06	0.3529E+04
Component	6	0.1472E+06	0.1601E+06	0.1294E+05	0.8000E+03
Component	7	0.1913E+04	0.5089E+05	0.4898E+05	0.1980E+04
Component	8	0.3958E+04	0.1039E+06	0.9992E+05	0.4035E+04

Figure 1 Excerpt from <filename>key.txt output file

The data includes:

- In water weight: submerged weight of component. *In air weight-In water buoyancy* [N].
 - In air weight: weight of component in air [N].
 - In water buoyancy: weight of displaced water if the component is submerged [N].
- Note (1).**
- Total length: total length of the component. In case of net, this is the total length of twines [m].

Note (1)

If “Water volume correction” is set to “With slamming” in AquaEdit, the input data should be given as if the component is below the water line. AquaSim adjusts the buoyancy if the component is above the water line (this is not applicable for membranes). If the “Water volume correction” is set to “None” or “Normal”, the user must input the correct buoyancy. AquaSim do not make any adjustments in these cases. Hence, applying “With slamming” is a more advanced option.

2.8 The <filename>val.txt

The objective of this file is for self-validation of input data such as area, moment of inertia, mass and added mass. Added mass is printed for components where the “Hydrodynamic” load formulation is applied.

2.9 The <filename>conv.txt

The <filename>conv.txt file provides information about status and convergence data during execution of analysis. Figure 2 shows an excerpt from the file.

```

CONVERGENCE NOT ACHIEVED AT          3500 ITREATIONS AT LOADSTEP          34
-365238.2          845931.0          39.38226
STEP          35  CONVERGENCE AT          3440 ITERATIONS  -628742.1
21030.08          0.9790540

```

Figure 2 <filename>conv.txt

The last three numbers of each step have the following meaning:

1. The difference between the norm in the current iteration and the previous iteration.
2. The norm in the current iteration.
3. The norm in the current iteration divided by the degrees of freedom of the full analysis.

For more information about convergence, reference is made to chapter 10.7.

3 FINITE ELEMENT ANALYSIS OF NONLINEAR SYSTEMS

The finite element method divides a structure into a finite number of elements. Finite element (FE) analysis is used to establish static or hydrodynamic equilibrium at a given time instant for each individual element and the whole system. To obtain equilibrium, the internal forces in an element must be equal to the external forces.

3.1 Fundamentals of FE analysis

In this chapter, a truss element is used as example for illustrating the fundamentals of finite element method. Figure 3 shows a truss element as a line between two nodes: node A and node B. The internal forces acting in the truss depends on the relative distance between the two nodes.

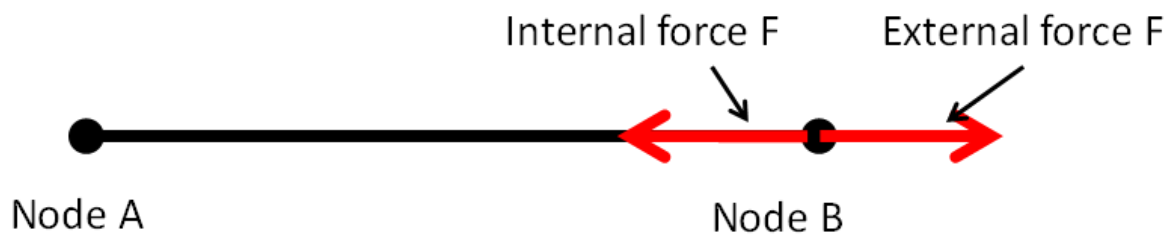

Figure 3 Truss element

Figure 4 depicts a truss element with node A fixed and the other one subjected to a force. The truss element will deform in a distance Δl . Hooke's law is a principle of physics that states that the force F needed to extend, or compress, a spring by the distance Δl is proportional to that distance. That is:

$$F = k \cdot \Delta l$$

Equation 1 Hooke's law

where k is the stiffness of the spring. The equation holds for linear-elastic or Hookean materials.

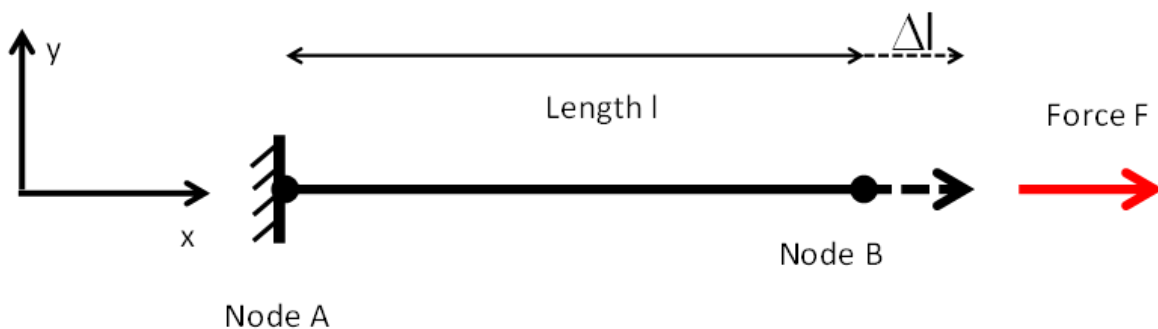
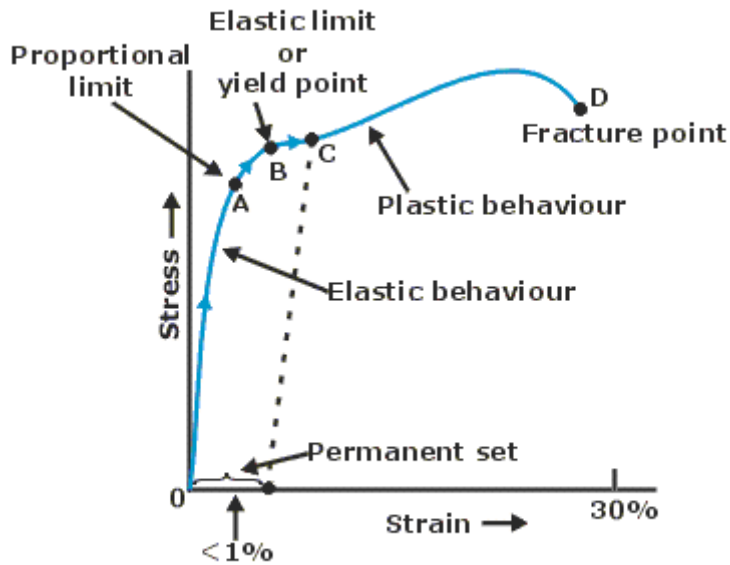

Figure 4 Hooke's law for an element

For typical metallic materials, Hooke's law is valid up to a proportional limit, as seen in Figure 5.



A typical stress-strain curve for a ductile metal

Figure 5 A typical stress-strain curve for a ductile metal

For further details on the FE method, see e.g. (Wikipedia, 2020a), (Bell, 1987), (Bergan & Felippa, 1985). For dynamic analysis, see (Bergan, Larsen, & Mollestad, 1982), (Langen & Sigbjörnsson, 1979).

3.2 Static analysis

In static analysis, inertia and damping forces are not accounted for. Equilibrium between external forces (\mathbf{R}_{ext}) and internal forces (\mathbf{R}_{int}) yields:

$$\Sigma \mathbf{F} = \mathbf{R}_{\text{ext}} + \mathbf{R}_{\text{int}} = 0$$

Equation 2

Where \mathbf{R}_{ext} is the external static forces acting on the structure at a given time instant, and \mathbf{R}_{int} is the internal forces. In the equations **bold** letters indicate matrices. In the FE method, the structure is discretized in a finite number of degrees of freedom (DOF's). Equation 2 is discretized into:

$$\mathbf{F}^{\text{idof}} = \mathbf{R}_{\text{ext}}^{\text{idof}} + \mathbf{R}_{\text{int}}^{\text{idof}} = 0, \quad \text{idof} = 1, N_{\text{dof}}$$

Equation 3

where N_{dof} is the discrete number of DOF's the structure has been discretized into. AquaSim deals with strongly nonlinear behavior, both in loads and structural response. To establish equilibrium in such systems, the tangential stiffness method is used. External loads are incremented to find the state of equilibrium. Having established equilibrium in timestep $i-1$, the condition for step i is predicted as:

$$\Delta \mathbf{R}^i(\mathbf{r}_{i-1}) = \mathbf{R}_{\text{ext}}^i(\mathbf{r}_{i-1}) + \mathbf{R}_{\text{int}}^{i-1}(\mathbf{r}_{i-1}) = \mathbf{K}_t^{i-1} \Delta \mathbf{r}$$

Equation 4

where \mathbf{K}_t^{i-1} is the tangential stiffness matrix. The external loads are calculated based on the configuration of the structure at $i-1$. This gives a prediction for a new set of displacements. Based on Equation 4 a prediction for the total displacement \mathbf{r} , is found as:

$$\bar{\mathbf{r}}_{j=1} = \mathbf{r}_{i-1} + \Delta \mathbf{r}$$

Equation 5

where j is the index used for the iterations. The bar on top of the letter \mathbf{r} indicates that it is a prediction. Based on the predicted displacement from Equation 5, forces are found and the residual forces is put into the equation of equilibrium as follows:

$$\Delta \mathbf{R}(\bar{\mathbf{r}}_j) = \mathbf{R}_{\text{ext}}^i(\bar{\mathbf{r}}_j) + \mathbf{R}_{\text{int}}^i(\bar{\mathbf{r}}_j) = \mathbf{K}_t^i \Delta \mathbf{r}$$

Equation 6

Equation 6 is solved with respect to the displacement $\Delta \mathbf{r}$. Incrementing j with one, the total displacement is now updated as:

$$\bar{\mathbf{r}}_j = \bar{\mathbf{r}}_{j-1} + \Delta \mathbf{r}$$

Equation 7

and Equation 7 is solved based on the new prediction for displacements. This is repeated until $\Delta \mathbf{r}$ is smaller than a tolerated error, then:

$$\mathbf{r}_i = \bar{\mathbf{r}}_j$$

Equation 8

Meaning that the prediction is considered good enough since the error is below the error threshold. When the tolerated error is reached, i is increased with one, and Equation 4 is carried out for a new load increment. **Note (2).**

Note (2)

It is also possible to carry out a static analysis for time dependent loads (for example wave loads). Then static equilibrium is established for the structure, neglecting structural velocity and accelerations. Alternatively, a dynamic analysis may be carried out. Note that the above equations are valid for translational motions. Euler angles cannot be used directly to handle large and time varying rotations. Therefore, AquaSim uses a tensor formulation for the rotations as outlined in e.g. (Eggen, 2000) and (Haugen, 1994). Using tensors, the vectors above are in fact matrices for rotational DOF's.

3.3 Dynamic analysis

Dynamic analysis estimates the response of systems in waves, where hydrodynamic forces are of importance (structural mass, added mass, damping, damping related forces). In general, Morison forces are relevant (Morison, Johnson, & Schaaf, 1950). The Morison load varies with the relative velocity between water and structure. The same algorithm used for the static load calculation is applied for the dynamic analysis, only in this case mass and damping forces are accounted for. The basic equation that needs to be solved is:

$$\Sigma \mathbf{F} = \mathbf{R}_{\text{ext}} + \mathbf{R}_{\text{int}} + \mathbf{R}_{\text{mass}} + \mathbf{R}_{\text{damp}} = 0$$

Equation 9

where \mathbf{R}_{mass} and \mathbf{R}_{damp} are forces originated from the structural mass and damping properties, respectively. In general, all the components in Equation 9 may depend on r , \dot{r} and \ddot{r} . Where r is the displacement, \dot{r} is the velocity of the structure, and \ddot{r} is the acceleration of the structure. However, in the present case not all components are dependent on all of r , \dot{r} and \ddot{r} :

$$\Sigma \mathbf{F} = \mathbf{R}_{\text{ext}}(r, \dot{r}) + \mathbf{R}_{\text{int}}(r) + \mathbf{R}_{\text{mass}}(r, \ddot{r}) + \mathbf{R}_{\text{damp}}(\dot{r}) = 0$$

Equation 10

The Newmark method (Newmark, 1959) is used for time integration in the dynamic analysis, the following constants are established:

$$a_1 = \frac{\gamma}{\beta h}, \quad a_2 = \frac{1}{\beta h^2}, \quad a_3 = \frac{1}{\beta h}, \quad a_4 = \frac{1}{2\beta} - 1, \quad a_5 = \frac{\gamma}{\beta}, \quad a_6 = \left(\frac{\gamma}{2\beta} - 1\right)h, \\ a_7 = a_5 - 1, \quad a_8 = (1 - \gamma)h, \quad a_9 = \gamma h$$

Equation 11

where γ and β are parameters in the Newmark methods, $\gamma = 0.5$ and $\beta = 0.25$ corresponds to the method of constant mean acceleration, see (Langen & Sigbjörnsson, 1979) pp. 258-259 for details and a schematic overview. h is the time increment Δt . Consider a time step i . The solution for time step $i-1$ is known. Our objective is to obtain equilibrium at this particular time step. A tangential stiffness matrix is established based on the structure's actual geometry at this particular time step, similar to Equation 4. An effective stiffness matrix is established:

$$\hat{\mathbf{K}}_t = \mathbf{K}_{i-1} + a_1 \mathbf{C} + a_2 \mathbf{M}$$

Equation 12

and an effective load vector is established:

$$\Delta \mathbf{R} = \mathbf{R}_{\text{ext}}^i(\mathbf{r}_{i-1}, \dot{\mathbf{r}}_{i-1}) + \mathbf{R}_{\text{int}}^i + \mathbf{R}_{\text{damp}} + \mathbf{C}b_i + \mathbf{M}a_i$$

Equation 13

where

$$\mathbf{a}_i = a_3 \dot{\mathbf{r}}_{i-1} + a_4 \ddot{\mathbf{r}}_{i-1}$$

Equation 14

and

$$\mathbf{b}_i = a_5 \dot{\mathbf{r}}_{i-1} + a_6 \ddot{\mathbf{r}}_{i-1}$$

Equation 15

Then solve with respect to displacements $\Delta \mathbf{r}$:

$$\Delta \widehat{\mathbf{R}} = \widehat{\mathbf{K}}_t^{i-1} \Delta \mathbf{r}$$

Equation 16

A prediction for the displacements $\Delta \mathbf{r}$ has been established, it is now iterated until dynamic equilibrium is achieved. Now:

$${}^0 \Delta \mathbf{r} = \Delta \mathbf{r}$$

$$\mathbf{d}_i = a_7 \dot{\mathbf{r}}_{i-1} + a_6 \ddot{\mathbf{r}}_{i-1}$$

Equation 17

The following approximations for r, \dot{r} and \ddot{r} are established:

$${}^{k-1} \ddot{\mathbf{r}}_i = a_2^{i-1} \Delta \mathbf{r} - \mathbf{a}_i$$

$${}^{k-1} \dot{\mathbf{r}}_i = a_1^{i-1} \Delta \mathbf{r} - \mathbf{d}_i$$

$${}^{k-1} \mathbf{r}_i = \mathbf{r}_{i-1} + \Delta \mathbf{r}$$

Equation 18

where k is iteration no. k . Based on these approximations for r, \dot{r} and \ddot{r} , the force imbalance is found as:

$${}^{k-1} \Delta \mathbf{R} = \mathbf{R}_{\text{ext}}^i({}^{k-1} \mathbf{r}_i, {}^{k-1} \dot{\mathbf{r}}_i) + {}^{k-1} \mathbf{R}_{\text{int}}^i + \mathbf{R}_{\text{damp}} - {}^{k-1} \mathbf{M} {}^{k-1} \mathbf{r}_i$$

Equation 19

The force imbalance is introduced to Equation 16:

$$\Delta \widehat{\mathbf{R}} = \widehat{\mathbf{K}}_t^{i-1} \Delta \mathbf{r}$$

Equation 20

and a new set of approximations for r, \dot{r} and \ddot{r} are established:

$${}^k \Delta \mathbf{r} = {}^{k-1} \Delta \mathbf{r} + {}^k \Delta \mathbf{r}$$

Equation 21

At each iteration, a convergence test is carried out. If the test is not satisfied, the k is incremented and Equation 21 is run for another iteration. If the convergence criterion is satisfied, then a new set of r , \dot{r} and \ddot{r} is established as:

$$\begin{aligned}\ddot{\mathbf{r}}_i &= \mathbf{a}_2 \Delta \mathbf{r} - \mathbf{a}_i \\ \dot{\mathbf{r}}_i &= \dot{\mathbf{r}}_{i-1} + a_8 \ddot{\mathbf{r}}_{i-1} + a_9 \ddot{\mathbf{r}}_i \\ \mathbf{r}_i &= \mathbf{r}_{i-1} + \Delta \mathbf{r}\end{aligned}$$

Equation 22

Load and stiffness properties of the elements depend on the structural geometry configuration. Both load and stiffness vary strongly from time step to time step, depending on the configuration of the structure at the give time step.

4 ELEMENT PROPERTIES, LOAD AND RESPONSE: TRUSS AND BEAM

The basic properties of elements in AquaSim are linear-elastic as described in chapter 3.1. For information about nonlinear relation between forces and response in elements, see chapter 8. This chapter describes the properties, load and response for truss and beam elements.

4.1 Truss and beam element

Truss and beam elements have several similarities. The main difference is that a truss element does not have bending resistance.

This section presents the properties of truss- and beam elements in AquaSim. These properties are given by the user in AquaEdit. In general properties consist of:

- Mechanical properties of an element
- Properties related to the cross section
- Properties related to how elements respond to loads

4.2 Local coordinate system

Each element in AquaSim have its own local coordinate system. For truss and beam the local coordinate system is defined by having the origin in node **A**, and the local x-axis runs from node **A** to node **B**, as shown in Figure 6.

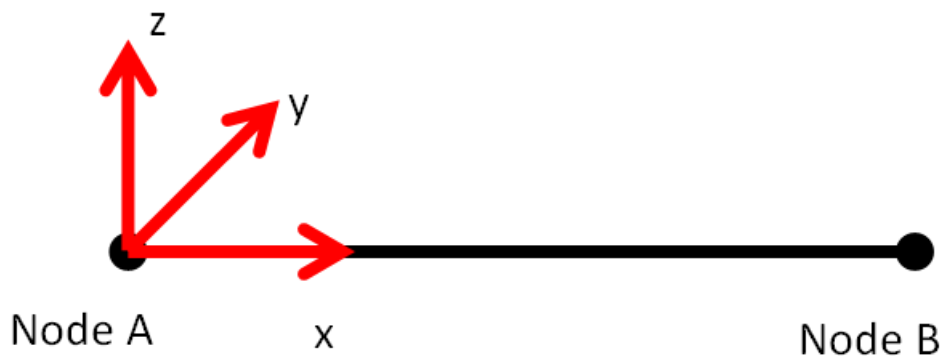

Figure 6 Local coordinate system of a truss or beam element

The coordinate system is an orthogonal coordinate system following the ‘right and rule’. The location of the local y- and z-axis is defined by the location of a virtual third node (Point 3). Point 3 is further described in chapter 4.24.

4.3 Stiffness matrix for truss element

Truss elements can take axial forces only. Consider a structural model where each node has 6 degrees of freedom with a truss connecting two nodes, see Figure 7. The origin of the local coordinate system is defined in node 1, with x-axis running from node 1 to node 2.

Translatory degrees of freedom

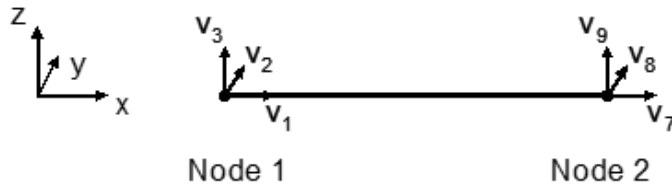

Rotational degrees of freedom, rotations about respective axes

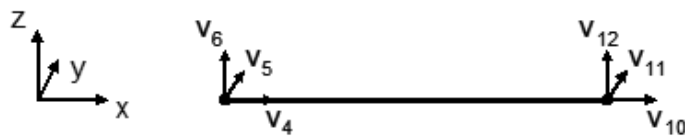

Figure 7 Truss element in a local coordinate system. Origin of local coordinate system is in node 1

The vectors v_1-v_3 is defined as translation in node 1 in x-, y- and z-direction, respectively. v_4-v_6 is rotation in node 1 about the x-, y- and z-direction. v_7-v_9 is translation in node 2 in x-, y- and z-direction, respectively. $v_{10}-v_{12}$ is rotation in node 2 about the x-, y- and z-direction. The local coordinate system is established for the actual position of the element depending on the actual coordinates of node 1 and 2, such that the local x-axis always goes from node 1 to node 2. The stiffness matrix for this truss element can be expressed as a 12 by 12 matrix, as shown in Equation 23:

$$k_{\text{mat}} = \frac{EA}{l_0} \begin{bmatrix} 1 & 0 & 0 & 0 & 0 & 0 & -1 & 0 & 0 & 0 & 0 & 0 \\ 0 & 0 & 0 & 0 & 0 & 0 & 0 & 0 & 0 & 0 & 0 & 0 \\ 0 & 0 & 0 & 0 & 0 & 0 & 0 & 0 & 0 & 0 & 0 & 0 \\ 0 & 0 & 0 & 0 & 0 & 0 & 0 & 0 & 0 & 0 & 0 & 0 \\ 0 & 0 & 0 & 0 & 0 & 0 & 0 & 0 & 0 & 0 & 0 & 0 \\ 0 & 0 & 0 & 0 & 0 & 0 & 0 & 0 & 0 & 0 & 0 & 0 \\ -1 & 0 & 0 & 0 & 0 & 0 & 1 & 0 & 0 & 0 & 0 & 0 \\ 0 & 0 & 0 & 0 & 0 & 0 & 0 & 0 & 0 & 0 & 0 & 0 \\ 0 & 0 & 0 & 0 & 0 & 0 & 0 & 0 & 0 & 0 & 0 & 0 \\ 0 & 0 & 0 & 0 & 0 & 0 & 0 & 0 & 0 & 0 & 0 & 0 \\ 0 & 0 & 0 & 0 & 0 & 0 & 0 & 0 & 0 & 0 & 0 & 0 \\ 0 & 0 & 0 & 0 & 0 & 0 & 0 & 0 & 0 & 0 & 0 & 0 \\ 0 & 0 & 0 & 0 & 0 & 0 & 0 & 0 & 0 & 0 & 0 & 0 \end{bmatrix}$$

Equation 23

where E is E-modulus, A is the cross-sectional area of the truss, and l_0 is the initial length of the element.

4.4 Stiffness matrix for beam element

The beam element is similar to a truss element. However, the stiffness matrix is different since a beam element also has resistance to bending. The stiffness matrix for beam elements can be expressed as (see e.g. (Bergan, Larsen, & Mollestad, 1982) and (Halse, 1997)):

$$k_{elem} = \begin{bmatrix} \frac{EA}{l_0} & 0 & 0 & 0 & 0 & 0 & -\frac{EA}{l_0} & 0 & 0 & 0 & 0 & 0 \\ 0 & \frac{12EI_z}{l_0^3} & 0 & 0 & 0 & \frac{6EI_z}{l_0^2} & 0 & -\frac{12EI_z}{l_0^3} & 0 & 0 & 0 & \frac{6EI_z}{l_0^2} \\ 0 & 0 & \frac{12EI_y}{l_0^3} & 0 & -\frac{6EI_y}{l_0^2} & 0 & 0 & 0 & -\frac{12EI_y}{l_0^3} & 0 & -\frac{6EI_y}{l_0^2} & 0 \\ 0 & 0 & 0 & \frac{GI_T}{l_0} & 0 & 0 & 0 & 0 & 0 & -\frac{GI_T}{l_0} & 0 & 0 \\ 0 & 0 & -\frac{6EI_y}{l_0^2} & 0 & \frac{4EI_y}{l_0} & 0 & 0 & 0 & \frac{6EI_y}{l_0^2} & 0 & \frac{2EI_y}{l_0} & 0 \\ 0 & \frac{6EI_z}{l_0^2} & 0 & 0 & 0 & \frac{4EI_z}{l_0} & 0 & -\frac{6EI_z}{l_0^2} & 0 & 0 & 0 & \frac{2EI_z}{l_0} \\ -\frac{EA}{l_0} & 0 & 0 & 0 & 0 & 0 & \frac{EA}{l_0} & 0 & 0 & 0 & 0 & 0 \\ 0 & -\frac{12EI_z}{l_0^3} & 0 & 0 & 0 & -\frac{6EI_z}{l_0^2} & 0 & \frac{12EI_z}{l_0^3} & 0 & 0 & 0 & -\frac{6EI_z}{l_0^2} \\ 0 & 0 & -\frac{12EI_y}{l_0^3} & 0 & \frac{6EI_y}{l_0^2} & 0 & 0 & 0 & -\frac{12EI_y}{l_0^3} & 0 & \frac{6EI_y}{l_0^2} & 0 \\ 0 & 0 & 0 & \frac{GI_T}{l_0} & 0 & 0 & 0 & 0 & 0 & \frac{GI_T}{l_0} & 0 & 0 \\ 0 & 0 & -\frac{6EI_y}{l_0^2} & 0 & \frac{2EI_y}{l_0} & 0 & 0 & 0 & \frac{6EI_y}{l_0^2} & 0 & \frac{4EI_y}{l_0} & 0 \\ 0 & \frac{6EI_z}{l_0^2} & 0 & 0 & 0 & \frac{2EI_z}{l_0} & 0 & -\frac{6EI_z}{l_0^2} & 0 & 0 & 0 & \frac{4EI_z}{l_0} \end{bmatrix}$$

Equation 24

where I_y and I_z is the second area moment of inertia about the local y- and z-axis. Area moment of inertia is further explained in chapter 4.8.

4.5 E-modulus

E-modulus or Elastic modulus (E), also known as Young's modulus or tensile modulus, is a measure of the stiffness of an elastic material. This is a mechanical property of a material. It is defined as the slope of the stress-strain curve in the range where Hooke's law holds, see Figure 5. In solid mechanics, the slope of the stress-strain curve at any point is called the tangent modulus. The tangent modulus, in the linear portion of the stress-strain curve, is equivalent to the Elastic modulus. Referring to Figure 5, this is the part of the curve up to yield point (B).

In AquaSim, if a component is not explicitly modeled with a nonlinear relation between stress and strain, the relation is linear-elastic. For linear-elastic behavior, the stress σ is found as $\sigma = E\varepsilon$, where ε is deformation.

4.6 Shear modulus G (shear)

The Shear modulus or Modulus of rigidity is denoted G . As for the Elastic modulus, the Shear modulus is a quantity measuring the stiffness of a material. It is defined as the ratio of shear stress to the shear strain. It is connected to the Poisson ratio ν , by:

$$G_{yz} = \frac{E_y}{2(1 + \nu_{yz})}$$

Equation 25

where yz is the plane of the cross section of the element. Truss elements have no shear stiffness. For information about Poisson ratio, please see e.g. (Wikipedia, 2020b).

4.7 Cross sectional area

A cross section is the intersection of a 3D object from the position of a plane through the object. When cutting an object into slices one gets many parallel cross sections. For 2-noded elements in AquaSim, the area, or cross sectional area, is the area of the object sliced in the yz -plane in an orthogonal coordinate system (and the x -axis running from node 1 to node 2). E.g. a cross section of a cylinder is a circle.

4.8 Area moment of inertia, I_y I_z

Area moment of inertia, also known as the second moment of area, moment of inertia of plane area, or second area moment, is a geometrical property which defines the resistance of a cross section to withstand deflection.

As an example, a filled rectangular area with a base width of b in the local y -direction and height h in the local z -direction has an area moment of inertia of:

$$I_y = \frac{bh^4}{12}$$

Equation 26

where I_y means about the y -axis, and

$$I_z = \frac{b^4h}{12}$$

Equation 27

where I_z means about the z -axis.

4.9 Area moment of inertia, torsion I_t

I_t or I_t is the area moment for resistance to torsion. Torsional motion is rotation or twisting of an object. In AquaSim, torsion is rotation of a beam element about the local x-axis as shown in Figure 8.

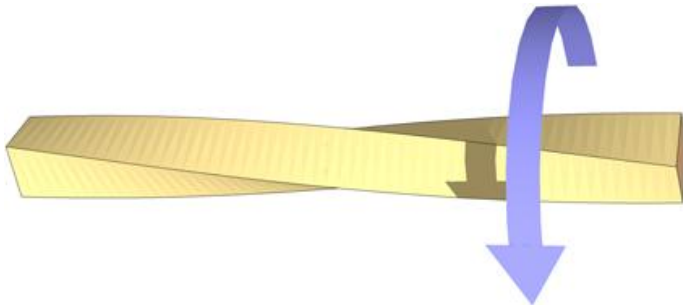

Figure 8 Torsion motion, from Wikipedia

A beam's resistance to torsion is given by Equation 28:

$$K_{torsion} = \frac{GI_t}{l_0}$$

Equation 28

where G is the shear modulus, as given in Equation 25. I_t is the torsional resistance and l_0 is the initial length of the beam. For circular sections, the cross section torsional resistance is the same as polar 2nd area moment of inertia.

4.10 Volume

Volume is the quantity of the three-dimensional space enclosed by a boundary. In AquaSim, the volume is given as cubic meter per meter [m^3/m]. From this volume, the buoyancy is calculated.

4.11 Weight and mass

The weight of an object is the force on the object due to gravity. Weight is introduced as mass per meter [kg/m] in AquaSim. Both weight in air and weight in water are input parameters. The default is to assign weight in air as input, as well as volume, for calculation of buoyancy. Based on this the relative weight in water is found from this. **Note (3)**.

Note (3)

The weight assigned to the element should include all weight carried by the element. If a tube is filled with water this means the element weight should include the weight of water in addition to the mass of the tube (calculated from mass density given as input). For selected predefined cross section, AquaSim provides option for filling of water. For more information, reference is made to the AquaEdit User Manual.

Utilizing the “Weight factor for slamming” combined with the water volume correction “With slamming”, AquaSim assumes that the object is empty of water when in air and waterfilled when below the instantaneous water surface.

Mass density refers to the quantity of matter in an object. More specifically, inertial mass is a quantitative measure of an object’s resistance to acceleration. Mass density is multiplied with the cross-sectional area and the length of the element to derive the element mass. In AquaSim, mass density is the mass per meter divided by the cross sectional area.

4.12 Pretension, pre-strain

The definition of pretension in AquaSim is pre-strain. As an example, 0.01 means that the element is assumed stretched 1% at the model configuration. **Note (4)**. The axial force is found as:

$$N = EA(l - l_0(1 - PRE))/(l_0(1 - PRE))$$

Equation 29

where:

- N is axial force
- E is Elastic modulus
- A is the cross-sectional area
- PRE is the pre-strain in the element, given as input in AquaSim
- l_0 is the initial length before applying the pretension (modelled length)
- l is the calculated/instantaneous length

Note (4)

It is possible to apply negative pre-strain as well.

4.13 Mass radius

Mass radius is the average mass radius with respect to rotation about the local x-axis.

4.14 Rayleigh damping

Rayleigh damping is given as a mass proportional term, and a stiffness term. Rayleigh damping is used to account for the fact that there are damping in a structure. If a structure is excited in a natural period, the amplitude will decrease over time, due to damping effects. Rayleigh damping is an approximation for the physical damping and should be used with care. The coefficients given into AquaSim is the factor the mass and stiffness matrix are multiplied with respectively to obtain the damping matrix caused by Rayleigh damping:

$$CR = C_m \cdot M + C_k \cdot K$$

Equation 30

where:

- CR is Rayleigh damping
- C_m is mass proportional Rayleigh damping, Rayleigh damping (mass)
- M is the mass matrix
- C_k is stiffness proportional Rayleigh damping, Rayleigh damping (stiffness)
- K is the stiffness matrix

C_m and C_k are the parameters given as input in AquaSim.

4.15 Shear stress, shear area

Shear stress is a stress-component parallel to an imposed force. For a rectangular cross section, the shear stress will be distributed as shown in Figure 9. Here, the shear stress is denoted S .

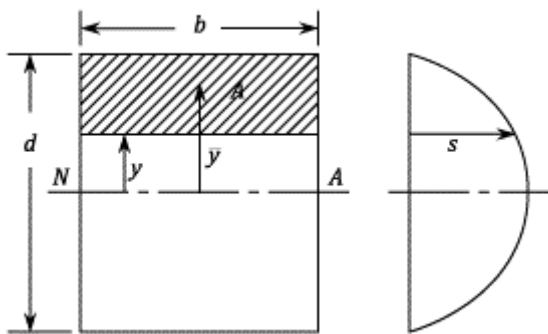

Figure 9 Shear stress distribution of a rectangular cross section

‘Kappa’ is a parameter normally set as the ratio between the maximum shear stress at the cross section and the average shear stress. In AquaSim, the shear stress is uniformly distributed over the cross section. In y -direction, the shear stress is multiplied with ‘Kappa Y’, and ‘Kappa Z’ in the z -direction.

4.16 Axial force

Axial force is a compressive or tension force acting in the lengthwise direction of an object. In AquaSim, this is the force acting in the direction from node 1 to node 2 of an element.

4.17 Shear force

Shear force are unaligned forces pushing one part of an object in one direction, and another part in the opposite direction in the plane perpendicular to the axial direction (the direction between node 1 and node 2).

4.18 Bending moment

Bending moment is the reaction in a structural element when a force or moment is applied to the element, causing the element to bend. Moments and torques are measured as a force multiplied by a distance. The unit is Newton-meters [Nm]. For linear-elastic response, the stress distribution caused by bending moment is shown in Figure 10.

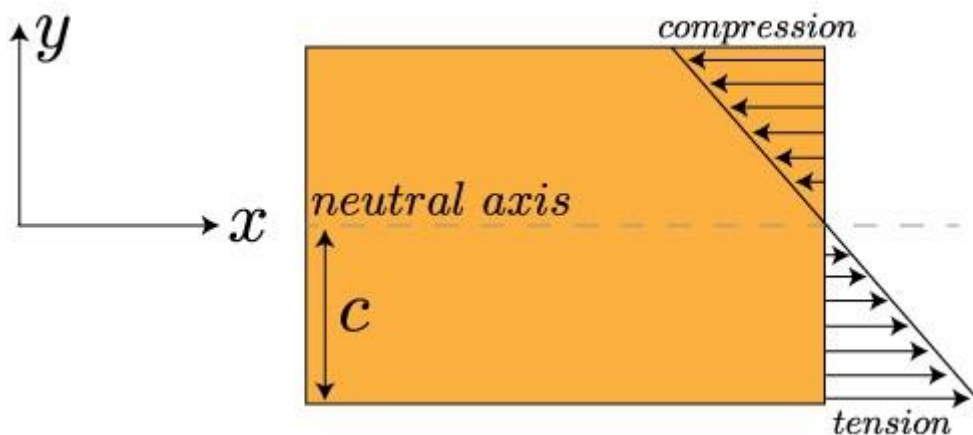

Figure 10 Stresses in a beam caused by bending moment over the cross section

4.19 Torsional moment

Torsion is the twisting of an object due to an applied torque, expressed in Newton-meters [Nm]. For a beam in AquaSim, this means torsional moment is moment about the local x-axis as shown in Figure 11.

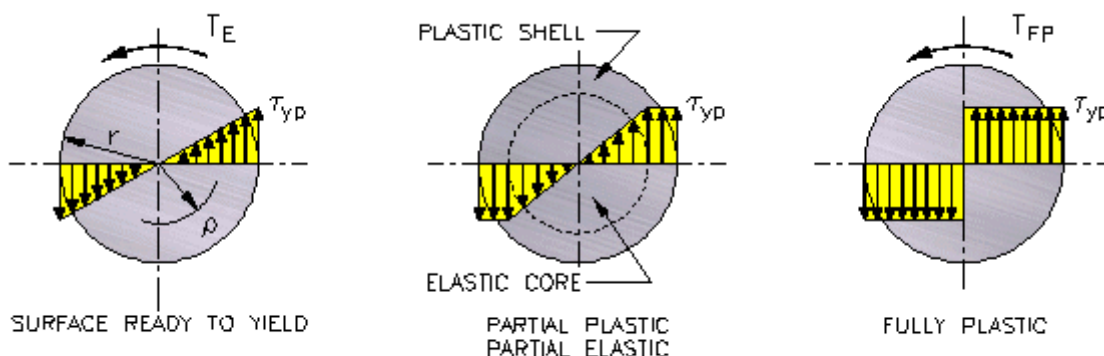

Figure 5 Torsion Stress Distributions

Figure 11 Stress from torsion

4.20 Wind load, response to wind

See chapter 4.23.10 for detailed description. Wind forces on truss are treated as equivalent for beams.

4.21 Longitudinal direction

4.21.1 Drag coefficient X

Adds drag in the longitudinal direction of the element. The drag is found based on the 2D-volume of the element.

$$F_{D(long)} = \frac{1}{2} \rho C_{D(long)} \cdot V_{2D} C_{Vol} \cdot L \cdot u |u| \quad [N]$$

where

- ρ is the density of fluid,
- $C_{D(long)}$ is the longitudinal drag coefficient,
- V_{2D} is the 2D volume of the element,
- $C_{Vol} = V_{sub}/V_{2D}$ is the relation between the submerged volume and total 2D volume,
- L length of element,
- u is the fluid velocity.

4.21.2 Added mass X

Adds added mass in the longitudinal direction of the element. The added mass is found based on the volume of the element. The inertia force (added mass and Froude-Kriloff) is found as:

$$F_{Inertia} = \rho V a + \rho V a C_{Mt}$$

Where

- ρ is fluid density 1025kg/m³,
- $V = V_{2D}L$ is the volume of the element [m³],
- L is the length of the element [m],
- a is the relative acceleration between the element and fluid particle due to waves [m/s²],
- C_{Mt} is the longitudinal added mass coefficient [-] (which is the input parameter to AquaEdit).

4.22 Morison load formulation: loads and coefficients

In AquaSim, one may choose to calculate forces on elements either by Morison equation (Morison, Johnson, & Schaaf, 1950) or as hydrodynamic (strip theory). This chapter describes the Morison load formulation. The equation for load introduced by the Morison equation is given by Equation 31. The cross-flow principle is utilized. The forces in the local y-direction will be:

$$F_2 = \underbrace{\frac{\rho_w C_{dy} Diam_N L_0}{2} (u_2 - \dot{v}_2) \sqrt{(u_2 - \dot{v}_2)^2 + (u_3 - \dot{v}_3)^2}}_{\text{Drag-term}} + \underbrace{\rho_w (1 + C a_y) V_{2D} L_0 a_2}_{\text{Froude-Kriloff diffraction}} - \underbrace{\rho_w C a_y V_{2D} L_0 \ddot{v}_2}_{\text{Added mass}}$$

Equation 31

where

- C_{dy} is the drag coefficient in the local y-direction. This corresponds to the input ‘Drag coefficient Y’ in AquaSim
- $\sqrt{(u_2 - \dot{v}_2)^2 + (u_3 - \dot{v}_3)^2}$ is the relative velocity between the element and the fluid in the cross sectional plane
- $Diam_N$ is the diameter of the cross section on the direction of the relative velocity
- $u_2 = u_{2wave} + u_{2current}$, where u_{2wave} is the fluid velocity due to waves, and $u_{2current}$ is the current velocity in the local y-direction
- \dot{v}_2 is the velocity of the element in the local y-direction
- a_2 is the fluid acceleration in the local y-direction
- $C a_y$ is the added mass coefficient, also in the local y-direction. See e.g. (Faltinsen, 1990)

In Equation 31, the first term is recognized as the Drag-term of the Morison equation. The second term is the combined Froude-Kriloff- and diffraction part of the load. The third part is the added mass. Similarly to Equation 31, the external force in the local z-direction is derived by substituting the y-direction with the z-direction:

$$F_3 = \frac{\rho_w C_{dz} Diam_N L_0}{2} (u_3 - \dot{v}_3) \sqrt{(u_2 - \dot{v}_2)^2 + (u_3 - \dot{v}_3)^2} + \rho_w (1 + C a_y) V_{2D} L_0 a_3 - \rho_w C a_y V_{2D} L_0 \ddot{v}_3$$

Equation 32

4.22.1 Added mass coefficient

Added mass coefficients are given explicitly for the y- and z-direction in AquaSim. The parameters given as input to AquaSim are the parameters recognized as $C a_y$ and $C a_z$ in Equation 31 and Equation 32. Note also how the added mass term also contribute to diffraction load in the Morison equation (see the second term in Equation 31 and Equation 32).

4.22.2 Diameter for drag, drag area

In Equation 31, $Diam_y$ corresponds to ‘Diameter for drag Y’ in AquaSim. Similarly, $Diam_z$ in Equation 32 corresponds to ‘Diameter for drag Z’ in AquaSim. The diameter in the direction of the relative velocity, $Diam_N$, is found from the input $Diam_y$ and $Diam_z$ with the assumption that these two diameters represents the largest and smallest diameter for an elliptic cross section. The drag diameter is equal to the physical diameter where the drag load acts.

Note (5).

Note (5)

$Diam_y$ refers to the diameter that is used to calculate drag force in the local y-direction of the element. If the user wants to use half the full diameter of the cross section, simply input half the value of the physical diameter in AquaSim.

In case AquaSim is used with the option ‘With slamming’, AquaSim calculates the submerged part of the cross section at all times and scales the drag area accordingly.

4.22.3 Wave generated damping coefficient

Wave generated damping, or wave induced damping is a damping mechanism where the object is damped due to propagation of energy away from the structure. These waves are generated by the object itself due to motions. For large-volume objects this damping may be of significance. In AquaSim, the user may apply this type of damping to elements with the Morison load formulation by applying coefficients in horizontal-, vertical- or rotational motion.

Calculation of damping force is based on (Faltinsen, 1990) Fig. 3.6.

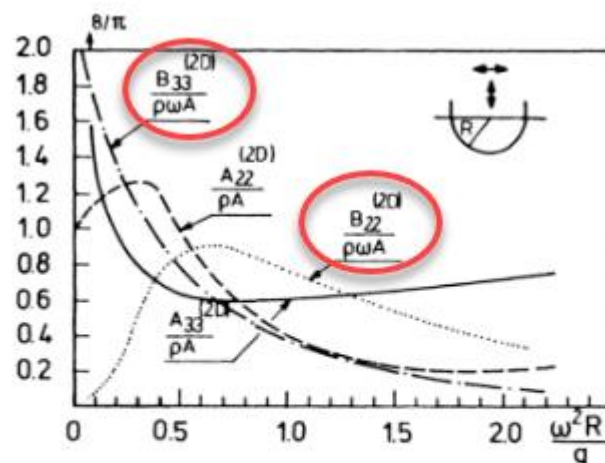

Fig. 3.6. Two-dimensional added mass and damping in heave and sway for circular cylinder with axis in the mean free-surface. Infinite water depth. $(A_{22}^{(2D)})$ = added mass in sway, $(B_{22}^{(2D)})$ = damping in sway, $(A_{33}^{(2D)})$ = added mass in heave, $(B_{33}^{(2D)})$ = damping in heave, ρ = mass density of water, $A = 0.5\pi R^2$, ω = circular frequency of oscillation).

Figure 12 Wave generated damping Fig. 3.6 from (Faltinsen, 1990)

The relation between the AquaSim input and the 2D coefficients from (Faltinsen, 1990) Fig. 3.6 is:

$$Horizontal = \frac{B_{22}^{(2D)}}{\rho\omega A}$$

$$Vertical = \frac{B_{33}^{(2D)}}{\rho\omega A}$$

Fig. 3.6 in (Faltinsen, 1990) does not provide a relation for rotational motion, but this is implemented to AquaSim as well.

The damping force for horizontal- and vertical motions is calculated in AquaSim as:

$$F_H = Horizontal \cdot \rho\omega A$$

$$F_V = Vertical \cdot \rho\omega A$$

Equation 33

4.22.4 Wave amplitude reduction and current reduction on Morison elements

Reduction of waves and current may occur due to shadow effects. Objects may be situated behind other elements, causing reduction of environmental loads. Reduction factors for wave amplitude and current can in these cases be applied. The input is a number between 0.0 and 1.0, and corresponds to a per centage of reduction. Applying Wave amplitude reduction will scale the wave amplitude ζ_A according to the input value. For current reduction, the drag coefficient C_D and drag diameter (“Diameter for drag”) are scaled according to the input value.

4.22.5 Lift

As an alternative to drag formulation for loads on submerged elements, data may be found from tables of drag, lift and yaw moment. As for drag loads, the cross-flow principle is assumed such that the loads refer to a local coordinate system where the local x - axis runs from node 1 to node 2. For deflectors, trawl doors or other parts where lift loads are applicable, input should be given as drag, lift, and yaw coefficients as a function of inflow angle.

Point 3 on the elements decides where the local z - axis is directed. An inflow angle of 0 means the part of the flow in the cross sectional plane (y - z - plane) is directed along the local z - axis. The parameters in AquaSim should be tested for response. In the table, the coefficients are given as angles. In between given angles, linear interpolation is used. End values are used outside the given interval. The lift-option is found under ‘Advanced’ in the Edit-beam window in AquaEdit. Input parameters to lift are:

- Input type: input may be given in Radians or Degrees
- Direction of lift: positive direction for an element (corresponding to 0 degrees angle of incident flow) is along the local z -axis. 1 means the lift direction is in accordance with a normed space. -1 means the inverse. This parameter may also hold the value -2. In this case, the rotation direction is opposite, but not the defined lift direction. -3 means that the lift direction is defined opposite, but not the angle.
- Diameter: chord diameter the coefficients are multiplied with.

- Angle: sets if there is an angle between the inflow and the local z-axis if the beam. If angle is 0, the local z-axis defines the 0-angle flow direction to the beam in the cross-flow plane. It is recommended to use 0 angle and direct the local z-axis to be in accordance with this. This is to avoid any miss on positive/negative angle.

Then the user should define a table where drag, lift and yaw are given as function of inflow angle of the fluid:

- Angle: inflow angle in the cross-flow plane relative to the local z-axis.
- Cd: drag coefficient in the direction of the flow.
- LiftCoeff: the lift coefficient. Factor for force 90 degrees to the flow direction in the cross-flow plane.
- YawCoeff: the yaw coefficient. Coefficient for rotation around the beam of the lift object.

Wave generated damping can also be included for motions in horizontal and vertical direction, and for rotations. These are added as coefficients, see section 4.22.4 for more information.

Running analysis with lift, a test of coefficients should be carried out to validate that coefficients are correct and have the correct sign. (Berstad & Tronstad, 2008) present a case for towed seismic equipment where lift elements are applicable for trawl doors.

4.22.6 Weight factor for slamming

If a cross section is waterfilled the 'Weight factor for slamming' will adjust the inner waterline to be proportional to the outer waterline. If the element is submerged, the inside volume is completely filled. The component should be given input data as completely filled. The 'Weight factor for slamming' should be a number between 0 and 1. The fraction of non-filled volume (compared to total inside volume) is given as input.

4.22.7 Use visual cross section as slamming

Not an available option for time being.

4.22.8 Wave- and current induced viscous drift force

The extra mean force due to waves and current is often referred to as viscous drift force. This type of drift force is automatically included in the AquaSim analysis when applying the Morison load formulation.

4.22.9 Wind load, response to wind

See chapter 4.23.10 for detailed description.

4.22.10 Include tangential Morison mass force

Hydrodynamic mass force can be added along the local x-direction (tangential direction) of the beam element. Forces in tangential direction for load formulation Morison submerged is expressed as:

$$F_1 = \underbrace{\frac{1}{2} \rho C_D A \cdot L \cdot (u_1 - \dot{v}_1) |u_1 - \dot{v}_1|}_{\text{Drag force}} - \underbrace{\rho V \cdot CM_{tan} \cdot a_1}_{\text{Hydrodynamic mass force}} \quad [N]$$

Equation 34

where

- Notation 1 indicates along local x-direction of the element,
- C_D is the drag coefficient in the local x-direction. This correspond to the input “Longitudinal drag coefficient” in AquaEdit *),
- A is cross sectional area of the element,
- L is the length of the element,
- $u_1 = u_{1(current)} + u_{1(wave)}$ fluid particle velocity,
- \dot{v}_1 velocity of the element,
- $(u_1 - \dot{v}_1)$ relative velocity between fluid and element,
- V volume of element that is submerged in fluid,
- CM_{tan} mass coefficient of the element. This correspond to “CM_tan factor” in AquaEdit,
- a_1 fluid particle acceleration due to waves in the local x-direction.

For more information, see (Faltinsen, 1990) Eq. (7.1).

*) For longitudinal drag forces to be included in AquaSim, one has to define values for drag in the section “Diameter for drag”. If values are not defined here, AquaSim will assume a rectangle with equal side lengths and calculate drag forces based on this.

4.22.11 Advanced buoyancy

Consider a vertical oriented beam, as shown in Figure 13. The lower part of the beam (Bottom) will experience a hydrostatic pressure that is higher than the top part of the beam (Top). This causes a net pressure difference on the beam, $p_{Net} = p_{Bottom} - p_{Top}$. When Advanced buoyancy is ticked on, this net pressure is removed. Meaning that $p_{Bottom} = p_{Top}$. The pressure on the beam’s sides will still follow Archimedes’ principle.

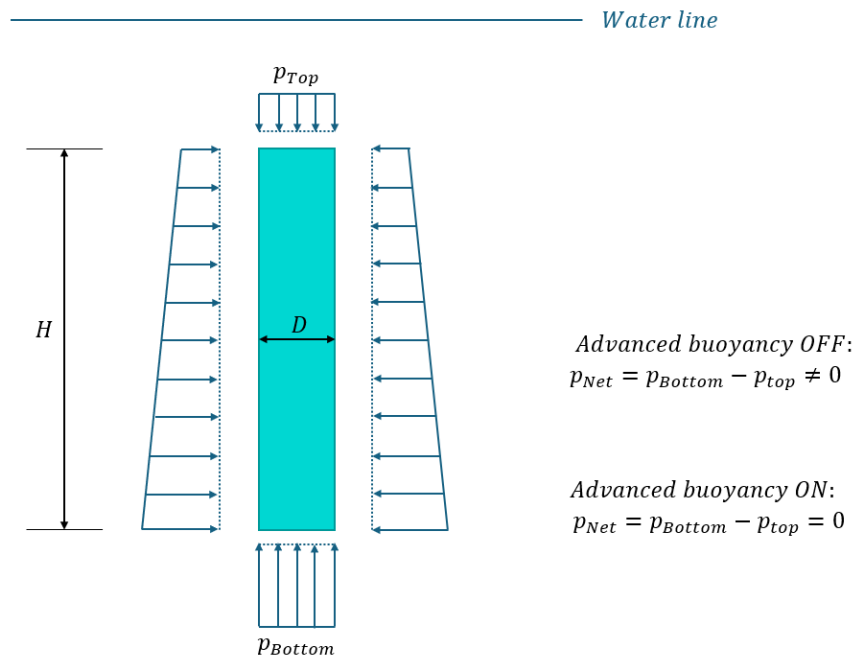

Figure 13 Submerged beam with height H and diameter D

4.23 Hydrodynamic load formulation: loads and coefficients

Hydrodynamic loads may be combined with the Morison equation loads. When choosing hydrodynamic loads only the drag term (the first term) of Equation 31 and Equation 32 is considered. The Froude-Kriloff and the diffraction loads in the Morison equation are calculated by strip theory. Also, the added mass is found by strip theory, such that the added mass coefficients of the ‘Drag load’ is omitted.

Using the hydrodynamic load formulation, hydrostatic stiffness in heave and roll are calculated based on the input of the section shape introduced by the user. Added mass, hydrodynamic damping, Froude-Kriloff and diffraction forces are calculated strip theory, see e.g. (Fathi, 1996) and (Berstad A. , 1999).

4.23.1 Strip theory

For typical floating components – from small parts such as polyester fish farm cage rings up to large structures like barges – hydrodynamic load formulation may be applied. In AquaSim, formulation must be applied to horizontal elements with penetration of the water line.

Figure 14 shows a square boxed fish farm cage in black to the left, and a barge to the right. The blue lines indicate how these structures may be subdivided with ‘strips’. A linear boundary value problem is solved for each strip. Linearized means that the boundary conditions are applied at their mean positions (see e.g. (Faltinsen, 1990) Ch. 4). A linearized boundary value problem is solved for a single frequency wave and wave heading.

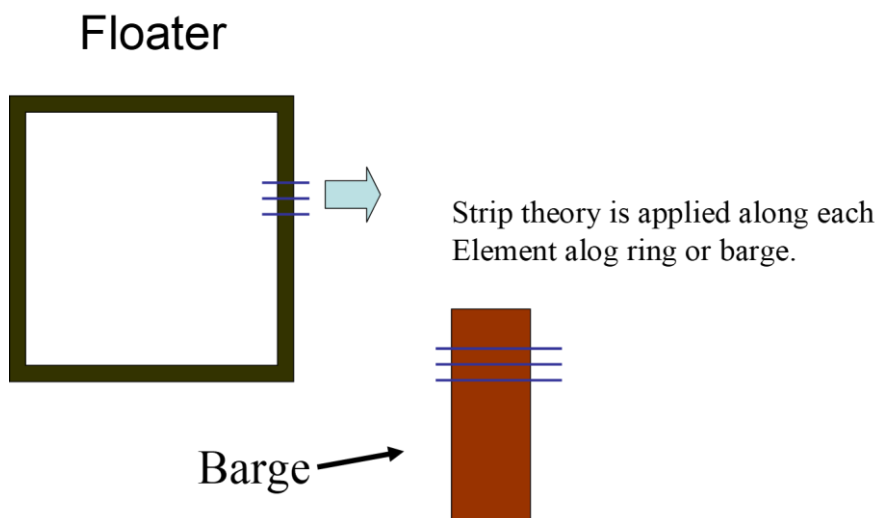

Figure 14 Square floater in black, and a barge seen in brown. Seen from above

The damping and added mass are derived at the peak period of the spectrum (in case of irregular seas). Whereas the diffraction and Froude-Kriloff components are derived for each individual frequency in the wave spectrum, and each wave heading.

The geometry of each element subjected to hydrodynamic loads, is described by a cross section at each node. Then the cross section may vary along the element. For elements with constant cross sections (typical barges), the two sides are equal.

The Froude-Kriloff force and diffraction force is calculated as follows:

- The midpoint of an element is derived for the given time instant.
- The angle of the element's longitudinal direction is derived for the same time instant.
- The relative angle between the element and the wave angle in the global coordinate system is derived for each considered wave frequency component.
- Froude-Kriloff forces are calculated at the instantaneous position of the vessel relative to the waves, whereas the diffraction force is computed by interpolation of the pre-calculated diffraction coefficients.

4.23.2 Hydrostatic force

In hydrostatic terminology, gravitational and buoyancy forces are referred to as restoring forces. The stiffness matrix due to restoring force, k_{rest} , is given as:

$$k_{rest} = \frac{\rho g l_o}{2} \begin{bmatrix} 0 & 0 & 0 & 0 & 0 & 0 & 0 & 0 & 0 & 0 & 0 \\ 0 & 0 & 0 & 0 & 0 & 0 & 0 & 0 & 0 & 0 & 0 \\ 0 & 0 & A_{wp} & 0 & 0 & 0 & 0 & 0 & 0 & 0 & 0 \\ 0 & 0 & 0 & \overline{VGM}_T & 0 & 0 & 0 & 0 & 0 & 0 & 0 \\ 0 & 0 & 0 & 0 & 0 & 0 & 0 & 0 & 0 & 0 & 0 \\ 0 & 0 & 0 & 0 & 0 & 0 & 0 & 0 & 0 & 0 & 0 \\ 0 & 0 & 0 & 0 & 0 & 0 & 0 & 0 & 0 & 0 & 0 \\ 0 & 0 & 0 & 0 & 0 & 0 & 0 & 0 & 0 & 0 & 0 \\ 0 & 0 & 0 & 0 & 0 & 0 & 0 & 0 & A_{wp} & 0 & 0 \\ 0 & 0 & 0 & 0 & 0 & 0 & 0 & 0 & 0 & \overline{VGM}_T & 0 \\ 0 & 0 & 0 & 0 & 0 & 0 & 0 & 0 & 0 & 0 & 0 \\ 0 & 0 & 0 & 0 & 0 & 0 & 0 & 0 & 0 & 0 & 0 \end{bmatrix}$$

Equation 35

where A_{wp} is the cross sectional (2D) waterplane area. For a beam element, the stiffness component of rotation about the local x-axis is also accounted for. V is the displacement, and \overline{GM}_T is the distance from the transverse metacentric height of the element to the center of gravity of the element (see e.g. (Wikipedia, 2020c) for definition of metacentric height). \overline{M}_T is found as:

$$M_T = B_C + \frac{I_{AWT}}{V_{2D}}$$

Equation 36

where B_C is the center of buoyancy calculated by AquaSim based on the (2D) volume. V_{2D} is the submerged volume. I_{AWT} is the 2nd area moment of inertia for the waterplane area. The parameter is calculated in AquaSim based on the intersection between the input geometrical data and the waterline.

In AquaSim, V_{2D} is calculated based on the hydrodynamic cross section defined under ‘Element loads’ and ‘Waterline Z’. **Note (6)**. In AquaSim, the waterline is defined at $z = 0$ in the global coordinate system. ‘Waterline Z’ enable the user to adjust the vertical position of the hydrodynamical cross section. If ‘Waterline Z’= 0, AquaSim calculates V_{2D} based on the drawn cross section. Applying negative values to ‘Waterline Z’ corresponds to increased V_{2D} and hence more buoyancy.

Note (6)

The ‘Information’-tab for beam elements enable the user to draw a visual cross section. For hydrodynamic load formulation, this cross section is only for visual purposes. Select ‘Copy to hydrodynamic’ to include the visual cross section in hydrostatic calculation.

G in the \overline{GM}_T is the center of gravity in the cross section, also referred to as ‘Mass center’. It should be noted that the ‘Mass center’ of the hydrodynamic element is assumed given in the same coordinate system as ‘Waterline Z’. Meaning that if ‘Waterline Z’ is set to 5m and the mass center is 5m, the mass center is in the water line when calculating \overline{GM}_T .. Other properties in the analysis, such as linearized diffraction force and added mass, is calculated based in the submerged volume and the location of ‘Waterline Z’.

When an analysis model is established, there might be a discrepancy between the waterline and the beam’s neutral axis. Note that when applying hydrodynamic load formulation, AquaSim is adapted for elements modelled horizontally.

4.23.3 Hydrodynamic length coefficient

For cases where hydrodynamic sections do not cover the full length of the geometric section, there is a possibility to model the sections in a simplified manner by using the ‘Hydrodynamic length coefficient’. When the full length of the section is in the water line, the factor should be 1. Reduced factor corresponds to reduced length of section intersecting the water plane.

Figure 15 show an example of how to apply the factor. To the left, a detailed render of a pier with pontoons intersecting the water plane. The total length of the pier is 10m and the pontoons are 1m wide. Hence, 30% of the total length intersect the water plane. To the right, a simplified render of the same pier with pontoons, modelled as one continuous beam. Applying a ‘Hydrodynamic length coefficient’ of 0.3 will then reduce the length of the beam intersecting the waterline to correspond with the more detailed model.

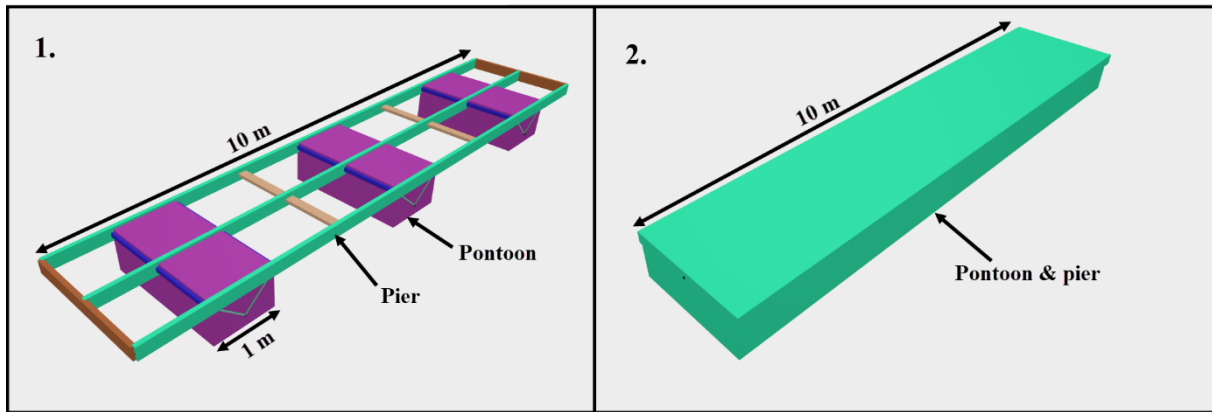

Figure 15 Left: pontoons modelled separately. Right: pontoons modeled as one section, length of section intersecting the waterline is reduced applying the 'hydrodynamic length coefficient'

4.23.4 Neutral axis Z

The 'Neutral axis Z' is the distance between the element's local coordinate system origin and the area center of the cross section.

4.23.5 Viscous roll damping

For roll motion of a ship shaped structure, vortices generated by the hull adds a significant contribution to damping. The user may account for this by applying the parameter 'Viscous roll damping'. Viscous roll damping is calculated as follows:

$$D_{rv} = \frac{A_{WP2D}^2 \rho_w}{8} D_{rvc} C d_r$$

Equation 37

where A_{WP2D} is the 2D waterplane area, ρ_w is the density of water, and $C d_r$ is the viscous roll damping coefficient. D_{rvc} is a factor depending on wave height and current velocity:

$$D_{rvc} = \max(\max(v_c, v_w) \cdot 0.7, 0.7)$$

Equation 38

where v_c is current velocity, v_w is max wave velocity (which is proportional to the wave height).

Consider the formula 7.26 in (Faltinsen, 1990):

$$F_n = \frac{\rho_w}{2} C_D b l |u| u$$

Equation 39

where F_n describe the normal force on a bilge keel, b and l are the length and width of the bilge keel, respectively. By linearization of Equation 39 and limit the equation to a 2D problem, then:

$$F_n = \frac{\rho_w}{2} C_D b |u_{lin}| u$$

Equation 40

Consider the corner of a vessel, where b_{vessel} is the width of the vessel:

$$u = \frac{b_{vessel}}{2} \dot{\phi}_4$$

Equation 41

where $\dot{\phi}_4$ is a velocity potential for rotation about the x-axis (i.e. roll motion).

Assume the bilge keel width is the part of a square vessel, then:

$$F_n = \frac{\rho_w}{2} C_D \frac{b_{vessel}}{2} |u_{lin}| \frac{b_{vessel}}{2} \dot{\phi}_4$$

Equation 42

The 2D vessel width, b_{vessel} , corresponds to the same as the 2D water plane area of the vessel, A_{WP} . This gives:

$$F_n = \frac{\rho_w}{2} C_D \frac{A_{WP}^2}{4} |u_{lin}| \dot{\phi}_4$$

Equation 43

When we introduce $u_{lin} = D_{rcv}$, and the fact that roll damping is defined as a force proportional with the roll velocity, we see that Equation 43 corresponds to Equation 37. Note that there are many approximations in this linearized equation. The cause of roll damping is due to drag forces, which result in a force proportional with the square of the relative velocity between the fluid and the object the fluid forces are acting on. To make a more physical correct assumption, one may model the bilge keel as eccentric beams longitudinally, close to the lower corner of the vessel. The beams should have a drag area corresponding to the effect of the corner of the vessel or to the actual bilge keel. In this case, drag load is calculated by the ‘normal’ drag load application meaning the damping will be quadratic.

4.23.6 Wave amplitude reduction and current reduction on hydrodynamic elements

As for beam elements with load formulation Morison submerged, hydrodynamic elements may also be defined with reduced wave amplitude and/ or current. Read more about it in chapter 4.22.4 and (Aquastructures, 2021c).

4.23.7 Horizontal components of hydrodynamic forces only

The option ‘Horizontal components of hydrodynamic forces only’, enable the user to omit hydrostatic forces and vertical hydrodynamic forces. AquaSim then sets these components to 0. In this case only horizontal components of the hydrostatic and hydrodynamic forces are accounted for.

4.23.8 Forces and load direction

AquaSim account for hydrostatic- and hydrodynamic forces. Hydrostatic forces include gravitational- and buoyancy forces. Hydrodynamic forces arise from velocity and acceleration of fluid particles due to waves or steady currents. Hydrodynamic forces are accounted for in all directions of a beam, but not normal to the cross section. Figure 16 illustrate a rectangle shaped object, representing e.g. a vessel hull, and the direction where hydrodynamic forces are not accounted for. To overcome this, the user may apply a secondary beam transverse of the longitudinal direction of the vessel hull (i.e. in the direction of the green axis). The length of the transverse beam should be equal to the width of the vessel **Note (7)**.

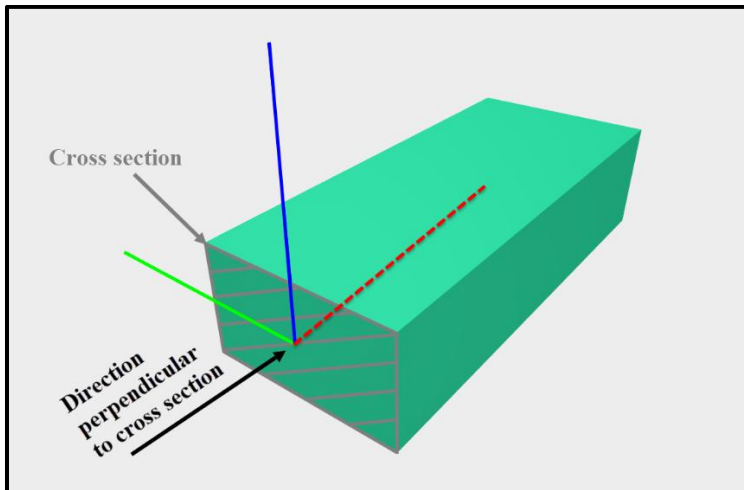

Figure 16 Direction of load perpendicular to cross section

Note (7)

In this case, overlapping elements will ‘double up’ the hydrostatic and vertical hydrodynamic forces of the object. To overcome this, select the ‘Horizontal components of hydrodynamic forces only’ for the transverse beam element.

4.23.9 Wave drift

AquaSim provides an option for including second order (mean) wave drift force when the Hydrodynamic load formulation is applied. This feature calculates the mean wave drift force according to the Maoruo formulation (see e.g. (Faltinsen, 1990)):

$$F_2 = \frac{\rho g}{2} A_r^2$$

Equation 44

where

- ρ is fluid density
- g gravitational acceleration
- A_r is the amplitude of the reflected wave

For regular waves, the drift force is constant, while for irregular seas it varies slowly with the wave envelope. When the period of an envelope coincides with a natural response period of

the structure, the corresponding drift excitation may become important. AquaSim accounts for variations in irregular sea states when calculating wave drift force.

To include calculation of the wave drift forces in AquaSim, the user should toggle on the checkbox ‘Drift’.

Reflected wave specifications:

In AquaSim, the reflected wave A_r can be determined in two ways:

- **Automatic Method (default):**
AquaSim automatically determines the reflected wave amplitude, when the checkbox ‘Drift’ is activated.
- **Manual scaling Method:**
The user can override the automatically determined amplitude by specifying how much of the incoming wave amplitude that should be reflected. This is done via toggle on the additional option ‘Amount of drift applied %’. If 1% is applied, this corresponds to 1% of the incident wave amplitude, or 75% corresponds to 75% of the incident wave amplitude, and so on.

Directional- and current corrections:

AquaSim calculates the reflected wave amplitude based on the assumption that the incident wave is normal to the element. For cases where the waves are not normal to the element (oblique), the mean wave drift force is corrected as:

$$F_2 = F_2 \sin^2(\beta)$$

Equation 45

where β is the angle between the incident wave and the intersection line between the element side and the water surface.

Current velocity is also accounted for. By adjusting Equation 45 (which correspond to Eq. 5.22 in (Faltinsen, 1990)) we have:

$$F_2 = F_2 \left(1 + \frac{\omega U \cos(\beta)}{g} \right)$$

Equation 46

where ω is the wave frequency and U is the current velocity.

Since the drift force follows the instantaneous water surface elevation, it introduces a sum-frequency load. Drift forces are calculated even when the ‘Horizontal components of hydrodynamic forces only’ is toggled on.

4.23.10 Wind load, response to wind

Beam elements can be exposed to drag loads from wind in AquaSim. In order to apply wind loads to beam elements, the element must be associated with a wind exposed drag area and wind drag coefficients. This area is added by the user. Two wind types are available for beams: Type 1 and Type 2. Wind exposed area is defined independently of the drawn ‘Visual cross section’, meaning that area is defined by height and width found in ‘Element loads’.

Wind Type 1:

The wind exposed area and drag coefficients is based on the input ‘Wind fetch’ and ‘Drag coefficients wind loads’ made available when selecting Type 1 from the drop-down menu. The area is calculated based on the assumption that the area is rectangular. ‘Max/ Min Y height’ represents one side of the rectangle, and the element’s length (along local x-direction) is the other side. The same apply to ‘Max/ Min Z width’.

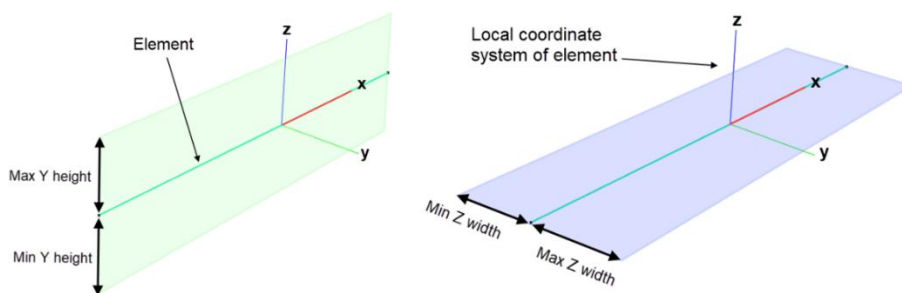

Figure 17 Wind exposed area, Type 1

Both ‘Max/ Min Y height’ and ‘Max/ Min Z width’ are given with reference to the element’s local coordinate system. Meaning that zero is in the element itself. AquaSim calculates wind velocity U based on an averaged z -position that takes the element’s vertical position and the extent of the area into consideration. The z -position is found as:

$$z_{wind} = z_{beam} + Min Y height + \frac{H}{2} [m]$$

Equation 47

where z_{wind} is the average vertical position that is applied in the calculation of wind velocity, z_{beam} is the position of the beam element, $Min Y height$ is input to AquaSim, and H is the height of the wind exposed area. This formula is applied for both local y - and z -direction.

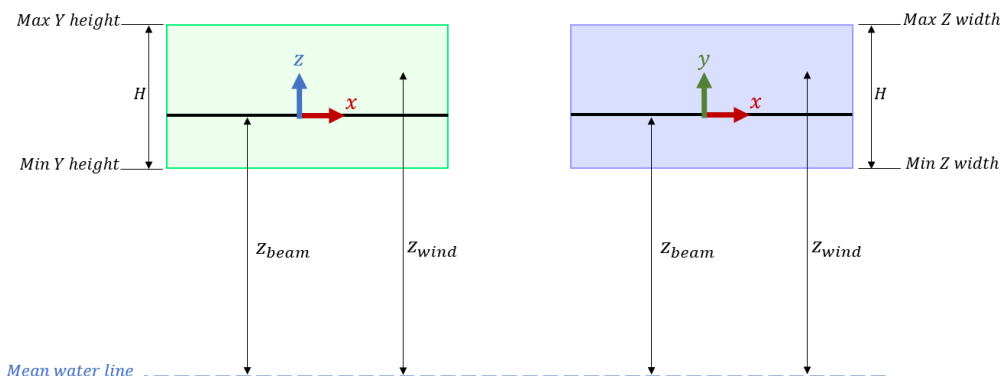

Figure 18 Average z -position applied in the calculation of wind velocity U

Wind Type 2:

The wind exposed area and drag coefficients is based on the input from ‘Diameter for drag’ and ‘Drag coefficients’ found under ‘Drag loads’. The area is calculated based on the assumption that the area is rectangular. Where ‘Y (depth)’ and ‘Z (width)’ represents one side of a rectangle, and the length of the element (along local x-direction) is the other side.

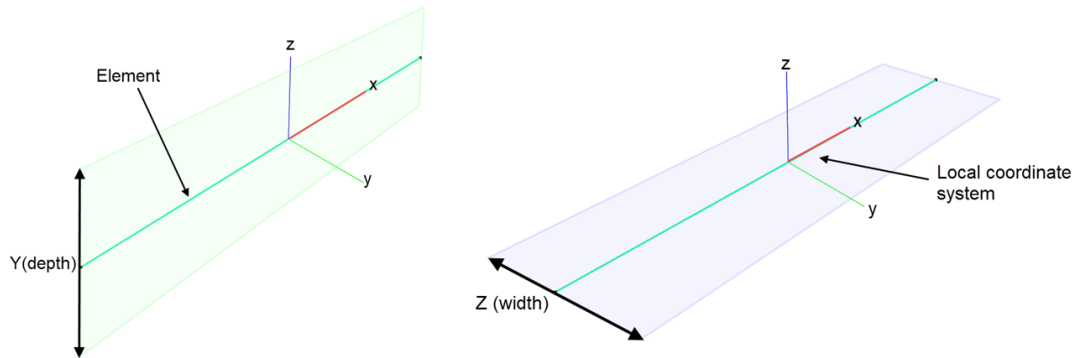

Figure 19 Wind exposed area, Type 2

AquaSim calculates wind velocity U based on the z -position of the beam, as illustrated below.

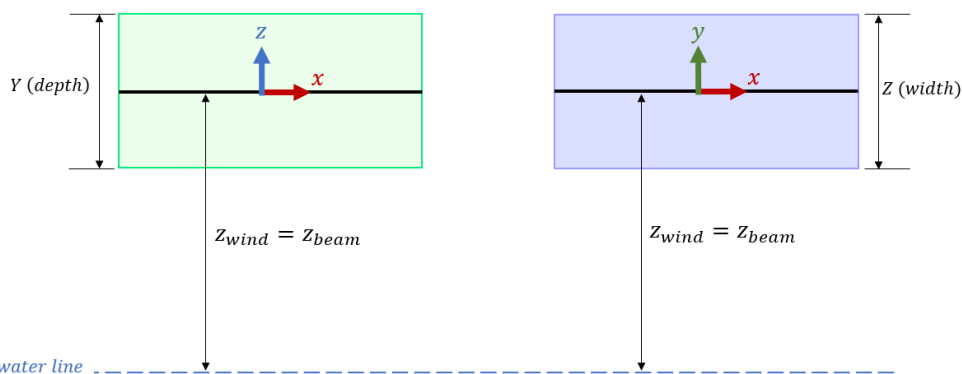

Figure 20 Average z -position applied in the calculation of wind velocity U

For regular mean wind (constant wind), the wind profile is calculated according to (Aquastructures, 2021a) Ch. 2.1.1. Irregular wind (wind gust) is calculated according to NORSOK N003 described in (Aquastructures, 2021a).

The force on a surface caused by the wind is then calculated by the following expression:

$$F_{wind} = \frac{1}{2} \rho_a C_D A \cdot U(z_{wind})^2 \quad [N]$$

Equation 48

where ρ_a is the density of air ($=1.27 \text{ kg/m}^3$), C_D is drag coefficient of the surface, A is the wind exposed area, and $U(z_{wind})$ is the wind velocity.

Note (8)

AquaSim automatically detect if the element is above, or below, the water line and include wind loads if it is above. This is the case independently of what is set at ‘Water volume correction’.

4.24 Point 3, node 3

Each beam and truss element have a ‘Point 3’ defining the direction of the local z-axis. Point 3 is defined as being in the positive halfplane on the local xz-plane, where the x-axis run from node 1 to 2. For beam elements, with hydrodynamic load formulation, Point 3 should be vertically above the element.

4.25 Hinge

A hinge keeps two adjacent parts together, typically is a door hinge as seen in Figure 21.

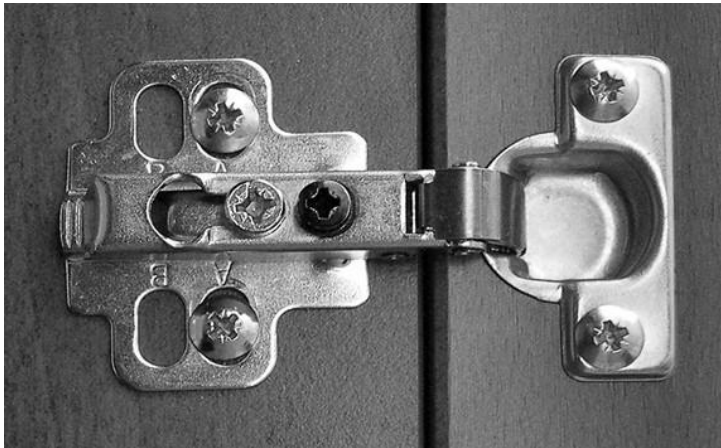

Figure 21 Example of two elements hinged together

In AquaSim, a hinge is introduced to one of the element’s node. Introducing a hinge means choosing if the node should be attached to other elements for each of the 6 DOFs of a node individually. The DOFs may be introduced either in the global coordinate system, or in a local coordinate system (the local coordinate system is applied to the hinge). The locale coordinate system is introduced by choosing ‘Co-rotated hinge’. The coordinates of the local x- and z-axis is defined in the Hinge-window in AquaSim. If a co-rotated hinge is chosen, the coordinate system of the hinge will rotate as the elements connected to the hinge rotates. For cases where elements rotate, it may be of importance to account for the rotation of the hinge points. Meaning that ‘Co-rotated hinge’ is often introduced to obtain this effect, even if the local coordinate system initially coincides with the global coordinate system.

4.26 Winch

Winching can be simulated in AquaSim. There exists two modes; winching out or winching in. For winching in, the winching length is at maximum the length of the element. For winching out, extra elements are added during the operation. One may winch out and introduce as many extra elements as one wish.

Winches are normally applied to truss elements. The winch speed is constant and equal to the velocity specified in the input.

4.27 Linebreak

It is possible to remove elements during the analysis based on some criteria. Useful to apply when simulating accidental limit states as an example. The break-criteria's that is available is:

- **Time:** the element will be removed at a certain time-step in the analysis. The user should input the analysis-step where the element should be removed.
- **Max force:** the element is removed when the axial force in the element exceeds the defined value. For each calculated time-step, AquaSim checks the value of the axial force on the element. If the axial force is below the Max force, nothing happens. If the axial force exceeds Max force, then the element is removed. The user should have in mind that AquaSim may not remove the element at the exact defined Max force because it only checks if the axial force is below or above the Max force for each time-step. To make this more accurate, the user should conduct a sensitivity study where the number of steps in the analysis is regulated.

4.28 Valve

Valves are normally applied to beam elements. Introducing valves provides the possibility to simulate that valve is opened at a certain timestep and water is filled to the defined volume inside the beam. Figure 22 shows a simplified case with a valve opened at the bottom of the cross section.

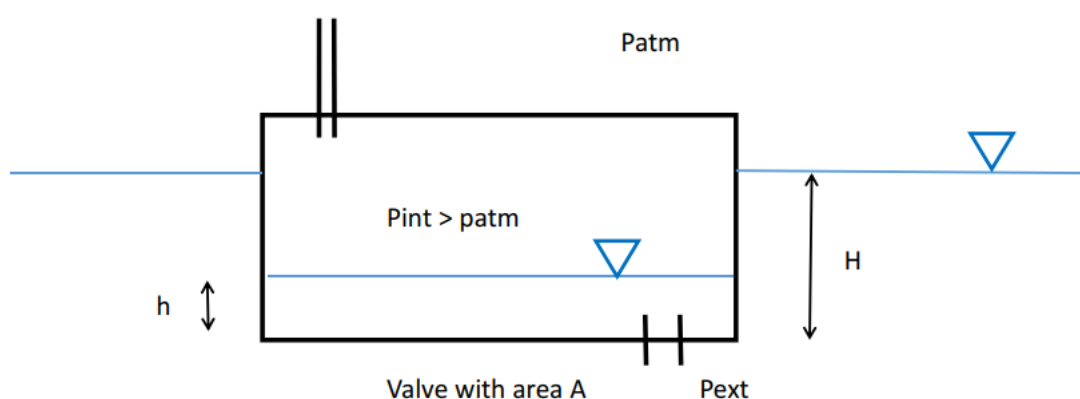

Figure 22 Principal sketch for valve in AquaSim

As seen in the figure, there is a height difference between the external surface and the internal surface. Applying Bernoulli's equation to the valve, the external pressure is as follows (velocity of the outside fluid):

$$p_{ext} = \rho g H + p_{dyn} + p_{atm}$$

Equation 49

where ρ is the water density ($=1025\text{kg/m}^3$) and g is the acceleration of gravity. H is the external height, and h is the internal height. p_{dyn} is the internal dynamic pressure calculated from hydrodynamic theory. p_{atm} is the atmospheric pressure. Bernoulli's equation gives the pressure from the outside to the inside of the valve:

$$p_{ext} = (1 + K_1) \frac{1}{2} \rho v^2 + \rho g h + p_{int}$$

Equation 50

where K_1 is the local friction in the valve. Combining Equation 49 and Equation 50 provides:

$$(1 + K_1) \frac{1}{2} \rho v^2 = \rho g (H - h) + p_{dyn} + p_{atm} - p_{int} = p_{delta}$$

Equation 51

where

$$p_{delta} = \rho g (H - h) + p_{dyn} + p_{atm} - p_{int}$$

Equation 52

The velocity v can then be found as:

$$v = \sqrt{\frac{2p_{delta}}{(1 + K_1)\rho}}$$

Equation 53

Consider now p_{delta} . This pressure depends on p_{int} which is unknown, so we need to find this. The other terms in Equation 51 are known. The amount of water passing through the valve at a given time instant is:

$$Q = Av = A \sqrt{\frac{2p_{delta}}{(1 + K_1)\rho}}$$

Equation 54

where A is the cross sectional area of the flow. The inside air needs to be moved from the air-filled inside the container to the outside atmosphere. To obtain this, the following has to be fulfilled:

$$p_{int} \geq p_{ext}$$

Equation 55

We assume that both the air and the water act as incompressible fluids. Continuum means that the flow of air out of the tube must be equal to the flow of water into the volume. This means that:

$$v_{airtube}A_i = v_{water inlet}A_y$$

Equation 56

The air outlet is a tube with a length typically in the range of 50-100 meters. Consider the time instant when the valve (for water inlet) is opened. At that time instant, the air outlet is already open, and the inside pressure is $p_{int} = p_{atm}$. Then the inside pressure will rise to a level that drives an air flow through the air tube. Applying Bernoulli's equation, the air from inside the tank to the atmosphere, the flowing equation is derived:

$$p_{int} = \left(1 + K_2 + f(Re) \frac{l}{d}\right) \frac{1}{2} \rho_{air} v_{air}^2 + p_{atm}$$

Equation 57

where l is the length of the tube, d is the diameter of the tube and $f(Re)$ is a function depending on the Reynold's number (see Figure 23). K_2 is a friction coefficient, which is different from 0, only if there is a valve in the tube.

Introducing Equation 57 to Equation 51:

$$(1 + K_1) \frac{1}{2} \rho v^2 = \rho g(H - h) + p_{dyn} - \left(1 + K_2 + f(Re) \frac{l}{d}\right) \frac{1}{2} \rho_{air} v_{air}^2$$

Equation 58

The Reynold number Re is in this case $Re = \frac{velocity_{air} \cdot Diameter}{Viscosity_{air}}$. $f(Re)$ is friction as a function of Reynolds number. A typical relation is shown in Figure 23 in terms of a Moody diagram. For laminar flow $64/Re$ is used. For turbulent flow $f(Re)$ is set to $\frac{0.31}{\sqrt[4]{Re}}$. Then there is a transition phase between laminar and turbulent flow. In this phase, $f(Re)$ is linearly interpolated between the Re number given as input to mark the highest Re for laminar flow and the Re value that is marked as the lowest Re where turbulent flow is applicable.

Moody Diagram

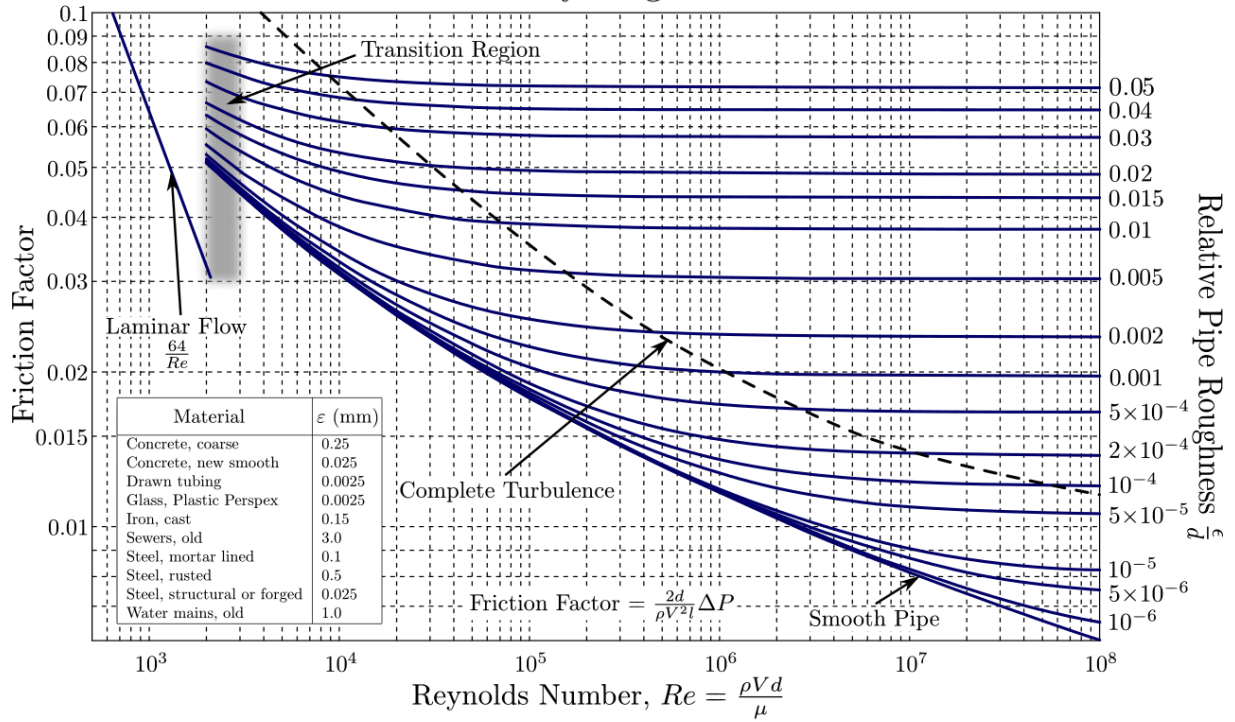

Figure 23 Moody chart (Wikipedia, 2020d)

4.28.1 AquaSim parameters for valve

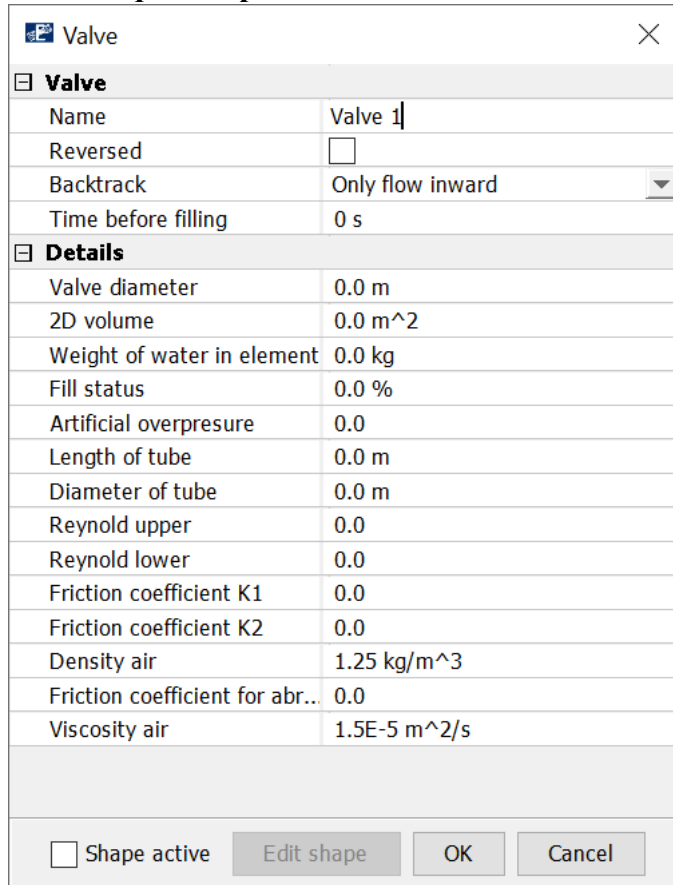

Figure 24 Input parameters for valve in AquaSim

The input parameters are set for the element the valve is attached to. The properties are:

Table 2 Description of input parameters for valve in AquaSim

Parameter	Description
Name	Name of the valve, set by the user.
Reversed	If not toggled, then the valve is placed at the elements first node (node A). If the user wants to apply the valve at the other node (node B), the simply toggle this option.
Backtrack	One may choose between ‘Only flow inward’, or the possibility of the flow to flow both ways, ‘Flow both ways’.
Time before filling	Time instant where filling starts, in seconds.
Valve diameter	Diameter of valve opening, according to Equation 54. Valve area is calculated from the diameter based on a circle.
2D volume	Defines the maximum allowed volume per meter water it is possible to add to the element.
Weight of water in element	This is the weight of water being stuck in the first element before spreading to the next element. When filling, it is assumed that the first element is filled to its capacity before water spreads to the next element.

Fill status	The fill status when the valve opens.
Artificial overpressure	It is possible to apply an overpressure in cases of blowing out water from elements.
Length of tube	This is the length of the air-tube out of the element to be water filled. Input in meters. This is the tube connecting the air inside the component being filled with water to free air. The smaller the tube, the more friction and slower filling.
Diameter of tube	Diameter of the tube out of the element being filled with water. Diameter of the tube from the abovementioned point.
Reynold upper	The upper limit for laminar flow. This is for air flow through the air tube.
Reynold lower	The lower limit for turbulent flow (this number is higher or equal to the upper limit of the laminar flow, it is interpolated with). If this number is set lower than the upper limit for laminar flow, the upper bound for the laminar flow will be set as also the lower bound of the turbulent flow.
Friction coefficient K1	In the case there is a valve in the opening where sea water flows into the element, this coefficient is used.
Friction coefficient K2	In the case there is a valve in the tube leading air out of the element being water filled, this coefficient is used.
Density air	The default value is set to 1.25kg/m ³ . The user may adjust this. The value is collected from Wikipedia.
Friction coefficient for abrasiveness	Coefficient applied to the air tube. Depending on implemented theory, see above.
Viscosity air	The viscosity of air. Default value is set to 1.5E-05. The user may adjust this. If the value is set lower than 1.0E-06, then AquaSim apply 1.0E-06.

4.29 Catenary slope

Catenary mooring systems are most common in shallow waters. The system will typically take the form of a free hanging line, with a part laying horizontally at the seabed. This is illustrated in Figure 25.

The Create Catenary slope, in AquaSim, allows to create catenary mooring systems based on user defined parameters. To create a catenary slope, the user must first create a guideline. The guideline is a straight line in XZ- or YZ-plane and defines the starting point of the slope and the vertical level of the endpoint of the slope. The input parameters are set for the selected element. The properties are:

Table 3 Description of input parameters in AquaSim

Parameter	Description
Force	The force applied to the mooring line at the fairlead.
Thread diameter	Diameter of the mooring line.
Submerged density	Density of the mooring line when submerged.
Divisions	Number of elements in the catenary slope.

The length of the catenary slope is calculated as:

$$S = \sqrt{D \left(\frac{2F}{w} - D \right)}$$

Equation 59

where

- F is the force applied to the mooring line,
- D water depth plus distance between seabed and fairlead (AquaSim automatically detects this by the vertical distance between the uppermost- and lower most node of the guideline),
- w density of the mooring line when submerged.

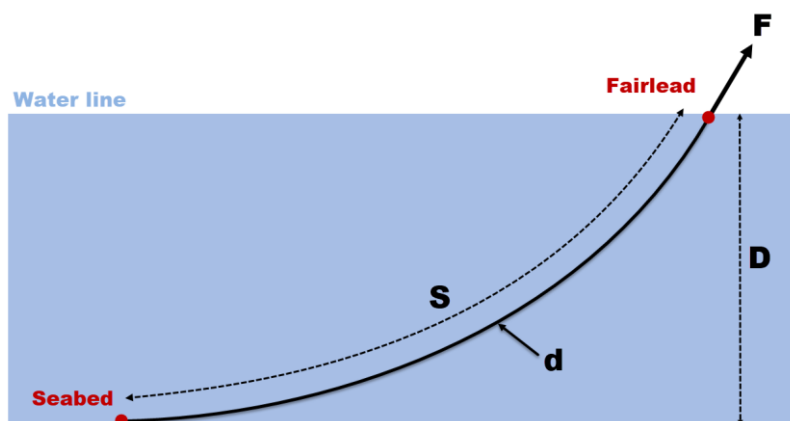

Figure 25 Catenary mooring, modified figure from (Catenary Calculator, 2021)

5 ELEMENT PROPERTIES, LOAD AND RESPONSE: MEMBRANE

AquaSim have a 4-noded element representing a rectangular part of a net as shown in Figure 27. The element can be at any shape, but the element assumes a twine follows the edge of the element.

5.1 Local coordinate system

A net element has a local coordinate system with the Y- and Z- axis in the plane of the element as seen in Figure 26. This is automatically defined by the geometry of the input, such that the local Z- axis run from node A to node B on the element. The local Z- axis run from node B to C on the element. For the side of a net this means that when results are taken from AquaView in terms of ‘Forces in horizontal twines’ and ‘Forces in vertical twines’ respectively this corresponds to actual vertical and horizontal twines. In general, the user must evaluate whether this is the case by evaluating where node A and B is on the element.

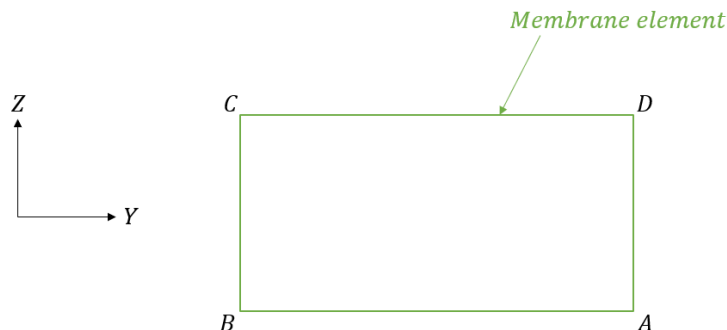

Figure 26 Membrane element in AquaSim

5.2 Structural properties of membrane type: Normal

In AquaSim, the membrane type *Normal* represents a pure membrane formulation. Meaning that the structural elements (twines) only account for axial forces. No bending moments or shear forces are transferred between the elements. Consequently, the membrane type *Normal* only exhibits in-plane tension stiffness (no out-of-plane bending stiffness).

The twines can be regarded as an idealized truss element in local direction, transferring only axial tension or compression. These assumptions make this membrane type suitable for representation of net panels and other highly flexible membranes where bending effects are negligible.

5.2.1 Mask Type 1

The element represents the number of twines crossing the line considered. As an example, if the distance between node 1 and node 2 in Figure 27 is 1 meter and the halfmesh size is 25 mm, 40 twines will cross perpendicular to the line between node 1 and 2.

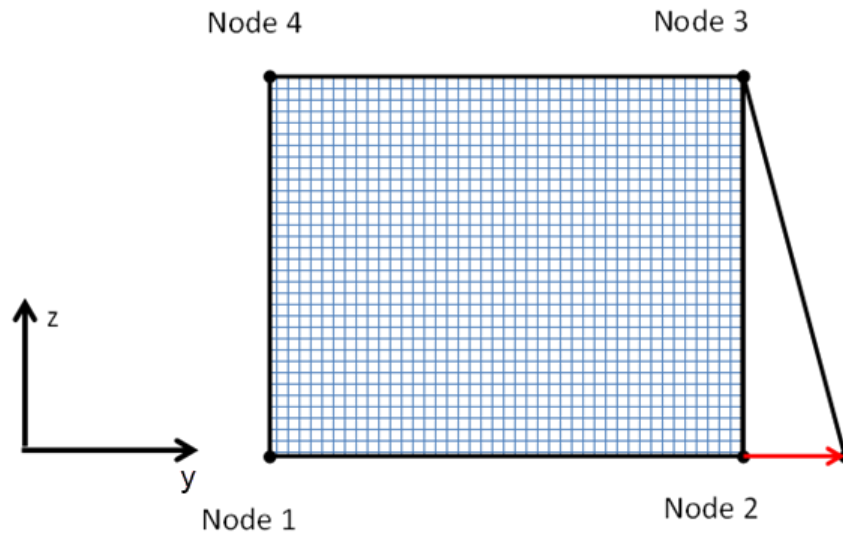

Figure 27 Net membrane element in AquaSim

For each node combination a form function as shown in Figure 27 is assumed. Such that if node 2 is moved along the positive x - axis and all other DOFs are fixed, the motion will introduce a strain to the horizontal net twines varying linear along the line between node 2 and node 3 as shown in Figure 27.

The membrane element may be permeable or impermeable with respect to water flow past the net. In both cases the structure of the net is assumed to be as shown in Figure 27. This means that also an impermeable net is assumed to be woven or have tissue in two directions like woven textiles. Cross sectional area and E-modulus should be chosen in accordance with each other and preferably be compare to elongation testing of the fabric.

For cases where the net element is not modeled rectangular, the direction of the individual twines will be as shown in Figure 28.

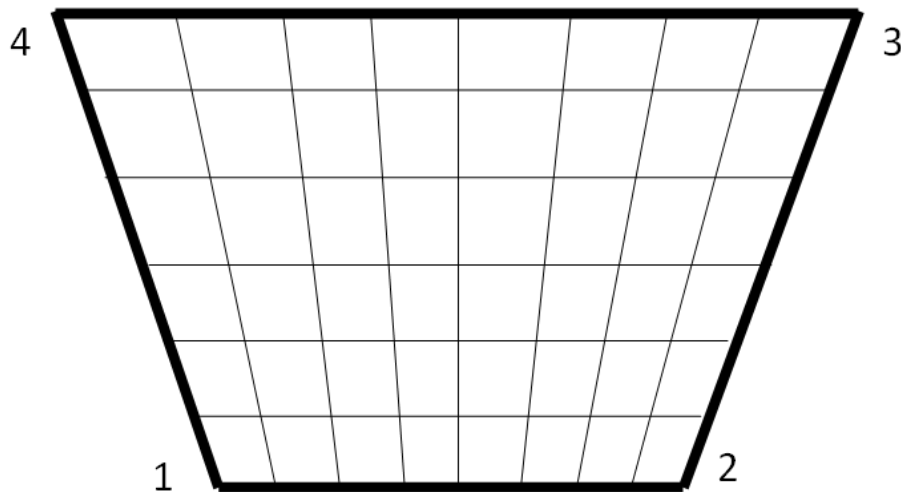

Figure 28 Thread direction for vertical threads

The number of twines along each line will not be as shown in Figure 28. Counting twines, each element side is treated separately such that line 3-4 will have more twines attached to it than line 1-2. When modeling the bottom of a net, one should be aware of this fact. As seen in Figure 29, forces will distribute along the net twines from the side net stave and downwards.

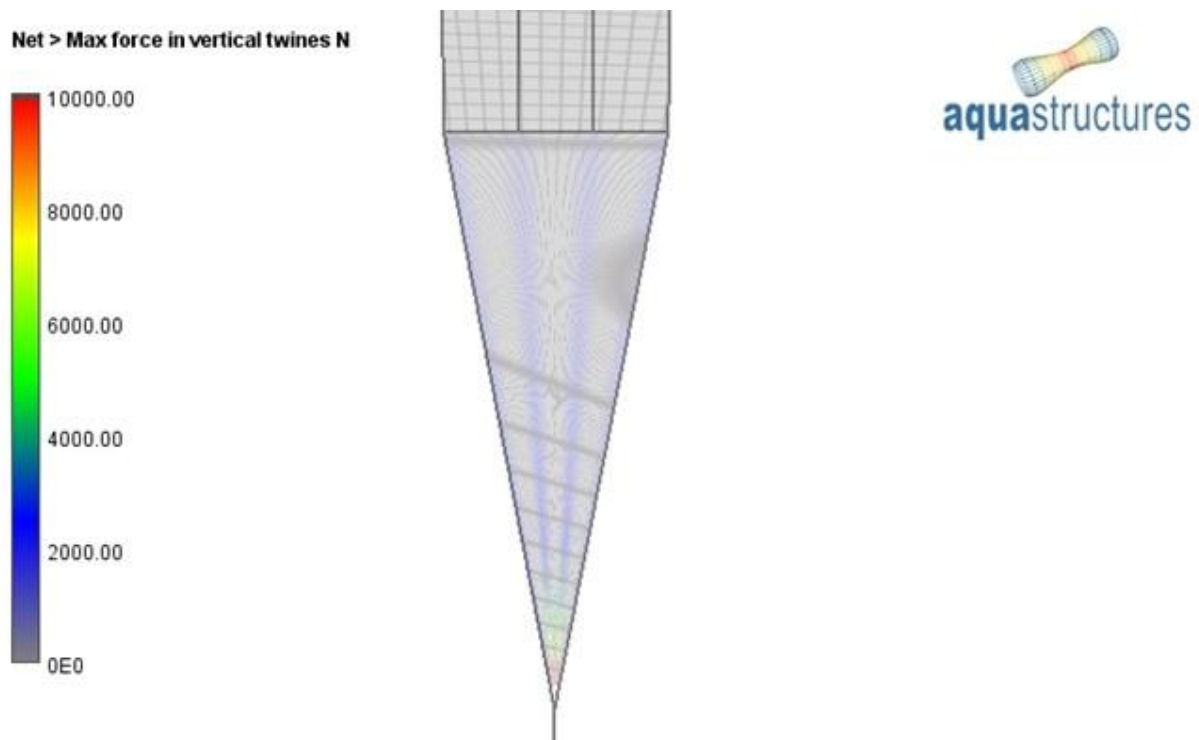

Figure 29 Forces in vertical twines, from AquaView

The case in Figure 29 is a simplified case with a wall sided square part on top with a conical part below. A node load is applied to the bottom of the model, while the top edge is fixed. The square part is 3 times more dense than the bottom. Meaning that there is no bottom rope taking over forces from the 2 of the side staves. As seen from Figure 29 this leads to high forces following the net twines all the way to the net bottom where the forces are transferred through the horizontal twines to the bottom ropes.

Figure 30 shows the bottom part of the net modeled with element making the twines run in parallel. In this case it is seen how forces are distributed to the bottom net staves much more evenly through the bottom net and the high concentration of forces close to the bottom of the net is avoided.

It is much easier to model the case seen in Figure 29 than the case in Figure 30. Most analysis models are hence made with the layout in Figure 29. This may lead to high, and artificial, stress concentration close to the bottom of the net. However, one should be aware that the bottom hole is a ‘focus point’ for forces, so care should be taken in design in all cases.

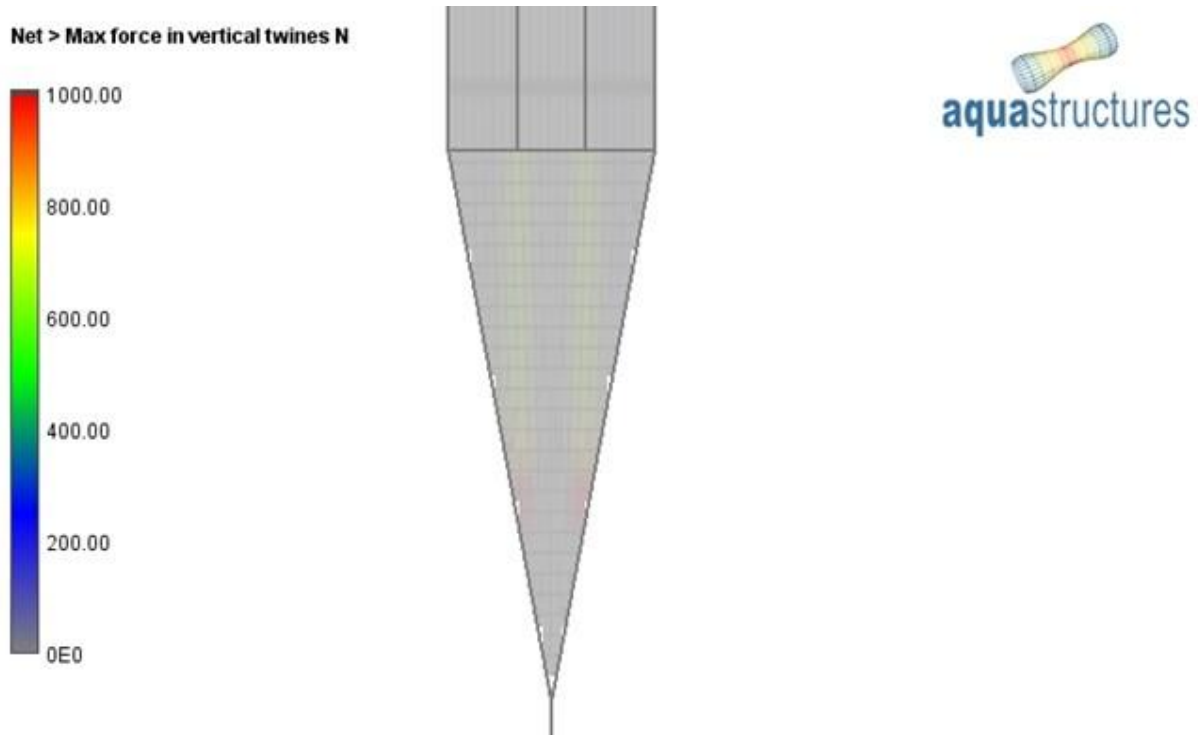

Figure 30 The conical part of the net modelled with parallel twines

5.2.2 Maskwidth Y and Maskwidth Z

Maskwidth Y is the distance between threads along line AB (and CD). Similarly, Maskwidth Z is the distance between threads along line BC (and AD). These are denoted L_y and L_z .

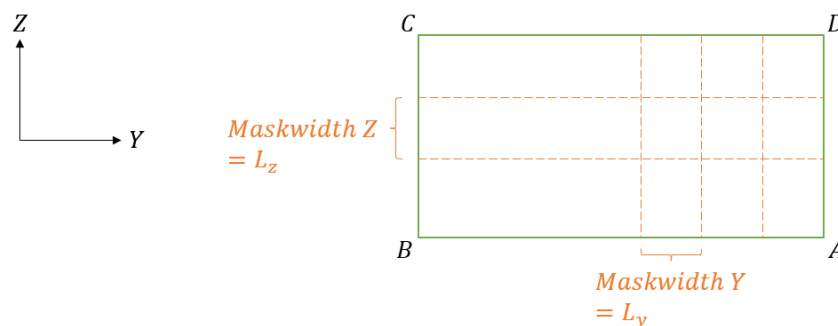

Figure 31 Definition of Maskwidth Y and -Z

5.2.3 Length of threads in local Y- and Z direction

The total length of threads in local Y-direction is along the sides AB (and CD). The total length of threads in local Z-direction is along the sides BC (and AD). These are denoted Lm_y and Lm_z .

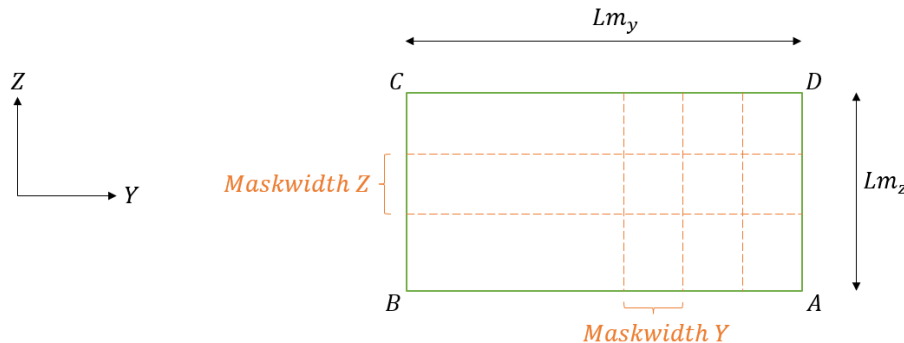

Figure 32 Definition of total length of threads

The total length of threads in each direction is calculated as:

$$Lm_y = AB \cdot \frac{BC}{\text{Maskwidth } Z}$$

$$Lm_z = BC \cdot \frac{AB}{\text{Maskwidth } Y}$$

As one can see from the equations above, the total length of threads is also dependent on the size of the modelled element. The length of line AB (and CD) will influence the length of threads in local Z-direction, and the length of line BC (and AD) will influence the length of threads in local Y-direction.

5.2.4 Pretension Y and Z

Pretension is the appliance of constant tension (or compression). In AquaSim this is done by either elongate or compressing the membrane element sides. In AquaSim one may apply pretension (positive or negative value) in local Y- and Z-direction by the input *Pretension Y* and *Pretension Z*. Note that when adjusting the pretension in AquaSim, the mask widths are kept constant.

The input values of pretension are given as a %-age of the initial length of the membrane sides. As an example, if Pretension Y=0.05, then the sides BC and DA are compressed by 5%. If Pretension Z=-0.1, then the sides AB and CD are elongated by 10%.

Pretension Y

When applying pretension in Y-direction, the vertical sides BC and DA are either elongated or compressed. Negative values will elongate the sides BC and DA. Positive values will compress the sides BC and DA.

- Pretension Y = negative values: BC and DA are elongated (meaning threads in vertical direction are stretched). Depending on the value of Pretension Y, more horizontal threads may be added.

- Pretension Y = positive values: BC and DA are compressed (meaning threads in vertical direction are shortened). Depending on the value of Pretension Y, horizontal threads may be removed.

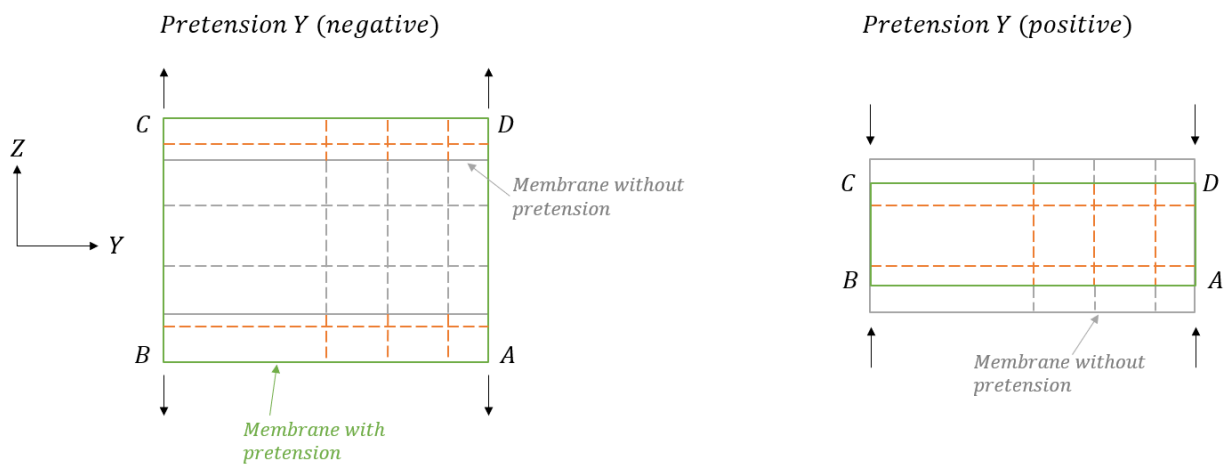

Figure 33 Definition of Pretension Y in AquaSim

Pretension Z

When applying pretension in Z-direction, the horizontal sides AB and CD are either elongated or compressed. Negative values will elongate the sides AB and CD. Positive values will compress the side AB and CD.

- Pretension Z = negative values: AB and CD are elongated (meaning threads in horizontal direction are stretched). Depending on the value of Pretension Z, more vertical threads may be added.

- Pretension = positive values: AB and CD are compressed (meaning threads in horizontal direction are shortened). Depending on the value of Pretension Z, vertical threads may be removed.

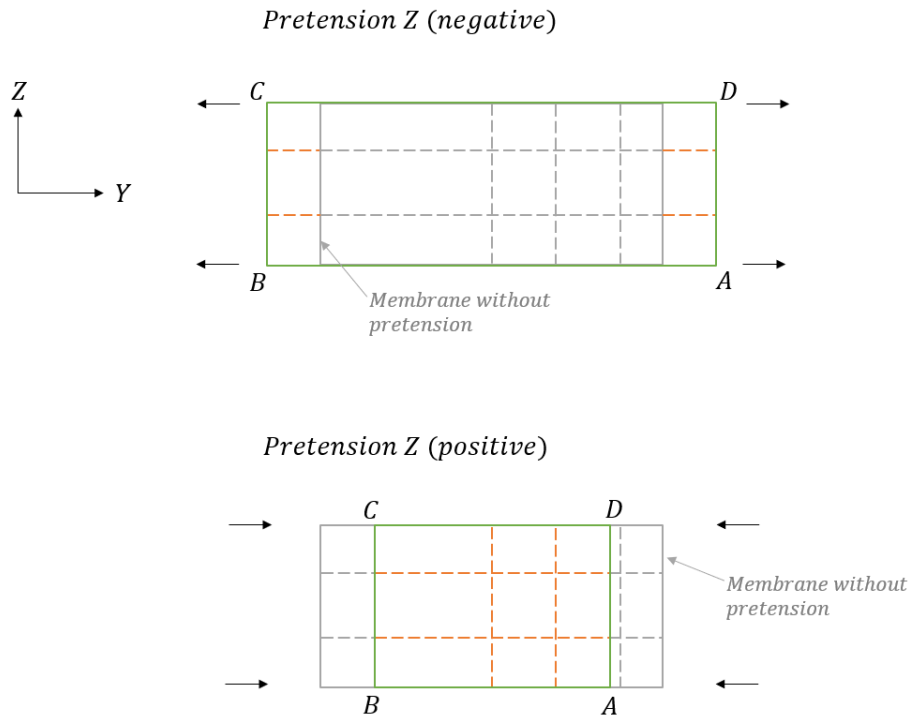

Figure 34 Definition of Pretension Z in AquaSim

Mask Type 2 (Diamond shaped)

AquaSim have an mask type representing a diamond shaped mesh as shown in Figure 35. In this situation, the assumed direction of mesh twine depends on the element shape. Such that the twines are assumed to have a direction from diagonal corners to diagonal corners as seen in the figure. The diamond shaped net can only be permeable and cannot have bending resistance.

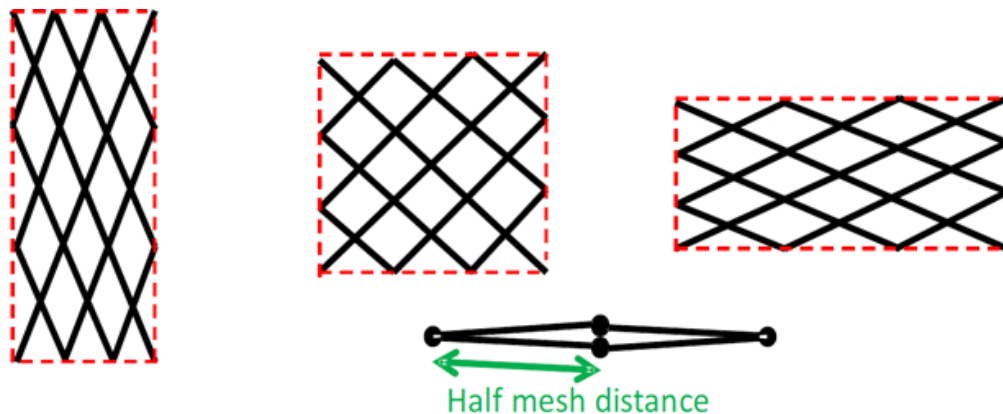

Figure 35 Diamond shaped mesh

Properties regarding load application and response are outlined in the succeeding chapters.

No compression

By activating this, twines in the net will not experience compressive forces. In AquaSim, the E-module will be reduced in the analysis in order meet the no-compression-criterion. It cannot be set exactly equal to zero due to numerical aspects. Due to this, the user may in certain cases experience some compressive forces in the net.

5.3 Structural properties of membrane type: Normal with bending stiffness

The membrane type *Normal with bending stiffness* is very similar to *Normal*. But extends by also including rotational stiffness into each twine, allowing some out-of-plane resistance in addition to the in-plane axial stiffness.

Each twine can to some extent be regarded as a beam element, where both axial forces and bending moments are transferred between the elements. Consequently, this membrane type can resist curvature and maintain its shape when exposed to transverse loads, but at the same time behave much like a flexible in-plane membrane.

Much of the input is the same as for type *Normal*, but in addition the user should specify bending stiffness properties such as moments of inertia, torsional stiffness and shear moduli. For more information about the structural properties, see section 5.2. These assumptions make this membrane type suitable for reinforced or semi-rigid net structures. The modeling approach and parameters are validated and documented in (Aquastructures, 2016).

5.4 Structural properties of 6-sided membrane

The *6-sided membrane* is modelled with 6-sided masks, or hexagonal shapes. Each modelled mask will represent smaller hexes according to the input thread diameter and mesh size.

Structurally, this membrane shares many of the same properties and mechanical behavior as component type *Truss*. Each twine is treated as an axial element that can take tension and compression, but no bending moments and shear forces. It therefore behaves as a network of *Truss*-like elements only capable of carrying in-plane axial forces. These assumptions make this membrane type suitable for net-pen structures, cage walls, fences and so on.

Theoretical formulation and validation of hexagon masks is found in (Aquastructures, 2022b). The mesh is created through a script, for more information on how to create hexagonal mesh reference is made to (Aquastructures, 2024b).

5.5 Structural properties of membrane type: Shell

In AquaSim, the membrane type *Shell* is a thin continuous panel with a finite thickness. It is capable of transferring both in-plane forces and out-of-plane bending moments and transverse shear.

Structurally, the *Shell* panel maintains its shape and resists curvature through its bending rigidity. The deformations are generally smaller compared with the other membrane types in AquaSim. The panel surface is treated as a continuous material, and not as discrete twines. The stress distribution is constant across the panel surface. These assumptions make this membrane type suitable for structural shells such as tank walls and stiffeners, covers and lids, or protective lids and so on.

Consider a four-node shell panel, as illustrated in Figure 36.

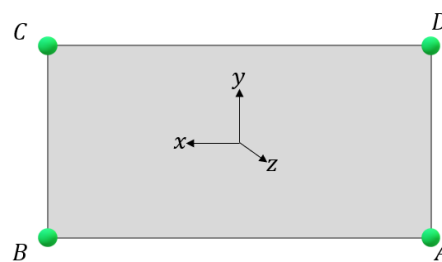

Figure 36 Shell panel in 2D

Each node on the panel has 6 degrees of freedom. A local coordinate system is established for each panel: the x-axis runs from node A to node B, y-axis is perpendicular to this and run from node B to node C. The z-axis points out of the plane. A four-node shell panel in 3D is visualized in Figure 37, with a mid-plane where the element nodes are located. Then an upper- and lower plane is defined through the panel thickness t .

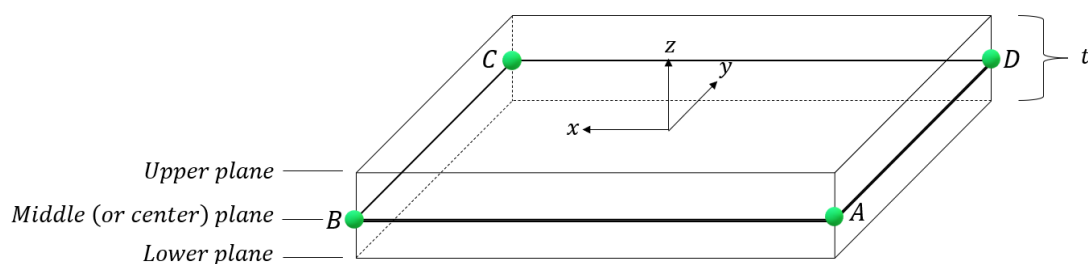

Figure 37 Shell panel in 3D

Shell elements employ ‘Quad 8’ from (Haugen, 1994), and only the isotropic material formulation is implemented, such that the input in AquaSim is:

- E-modulus: the elastic modulus representing the material, E .
- Thickness: thickness of the shell, t .
- Poisson: the material’s Poisson ratio, ν .

In contrast to membrane type Normal, shell do have resistance to bending. The middle plane represents the neutral axis. Shell elements are also described in (Aquastructures, 2020b).

5.6 Load formulation membrane: Regular net

In AquaSim, the load formulation *Regular net* represents a permeable surface where fluid can flow through, such as fish cage nets and other permeable marine structures. The *Regular net* consists of a large number of thin cylindrical twines arranged in a mesh pattern. It converts the interaction between fluid flow and individual twines into equivalent membrane-level hydrodynamic forces through an effective drag coefficient.

Detailed information and mathematical expressions are found in (Aquastructures, 2025f) and (Berstad A. , Drag Loads to Aquaculture Nets and the Corresponding Flow Velocity Reduction Behind, 2025). More historically development of this load formulation is found in (Berstad, Walaunet, & Heimstad, Loads From Currents and Waves on Net Structures, 2012).

5.7 Load formulation membrane: Lice skirt

A lice skirt is an impermeable membrane, or net, installed on aquaculture cage systems to prevent salmon lice from entering the cage system.

Because the skirts are impermeable, the fluid flow on the outside cannot flow through and has to find a way around. This causes the fluid on the outside and inside to accelerate with the structure, giving rise to added mass and damping effects. Compared with traditional aquacultural nets the external hydrodynamic forces therefore shift from being largely drag-dominated to being more mass- and inertia-dominated since the fluid moves with the skirt.

Detailed information about the theoretical basis and input-parameters are found in (Aquastructures, 2025a) and (Aquastructures, 2025b).

5.8 Load formulation: Closed compartment

In AquaSim, the *Closed compartment* load formulation represents a fully, or partially, sealed compartment. Because the compartment holds a volume of fluid, and has no flow-through, the hydrodynamic behavior differs from conventional nets where fluid flow is allowed to pass through the barrier.

Since the compartment contains internal fluid volume, the loading includes the effect of internal fluid mass inertia, added mass and damping due to motion of the structure.

Detailed information about the theoretical basis and input-parameters are found in (Aquastructures, 2025a) and (Aquastructures, 2025b).

5.9 Load formulation: Surface tarpaulin

In AquaSim, the load formulation *Surface tarpaulin* represents an impermeable sheet positioned horizontally at the water surface. Because the tarpaulin is located at the free surface, the hydrodynamic loading acts differently than for other types of structures that are fully- or partially submerged.

Surface tarpaulins are characterized by its flexibility and its highly coupling to the fluid motions. Detailed information about the theoretical basis and input-parameters are found in (Aquastructures, 2025d) and (Aquastructures, 2025c).

5.10 Load formulation membrane: Morison free plate

Morison free plate is a load formulation that applies the Morison equation to calculate forces on membrane elements using the cross-flow principle. This formulation is applicable for the membrane types; ‘Normal’, Normal with bending stiffness’ and ‘Shell’. An example of Morison free plate is shown in Figure 38. For theoretical formulation and validation, please see (Aquastructures, 2025e).

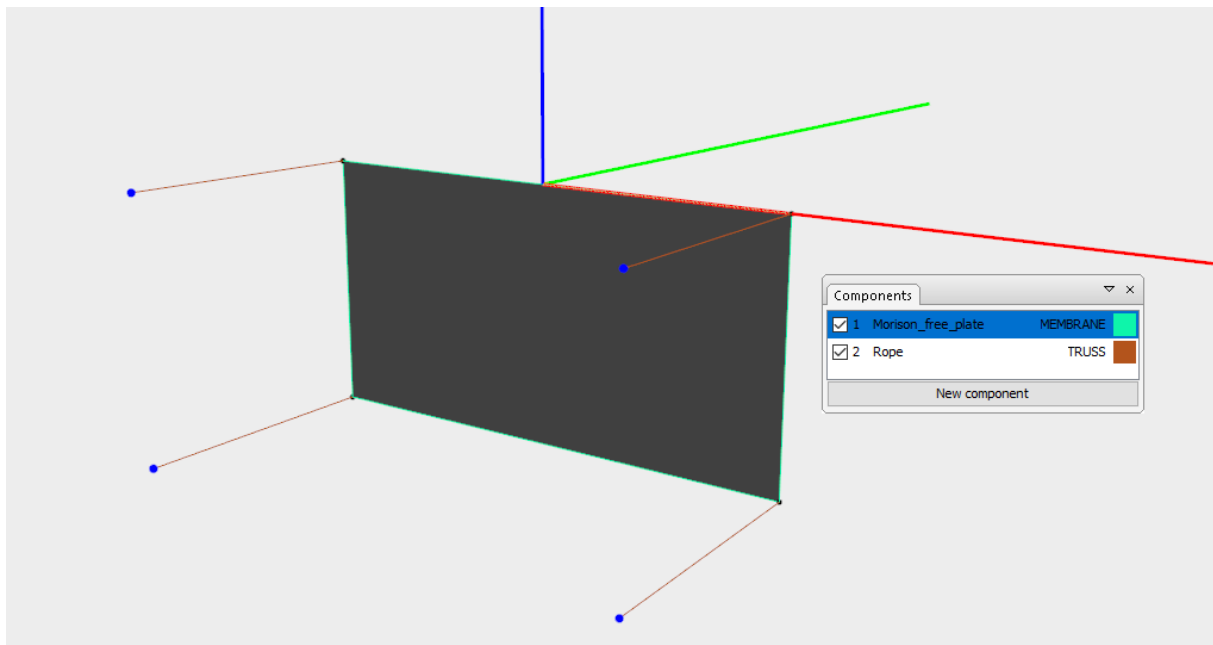

Figure 38 Membrane element modelled in AquaSim, applying Morison free plate load formulation

5.11 Current reduction on membrane

Note: In AquaSim version 2.20, the drag coefficient for nets has been revised, as well as there has been implemented an alternative current reduction method. For details see (Aquastructures, 2024d) and (Aquastructures, 2024c), respectively.

Current will be reduced for succeeding nets according to (Løland, 1991). Consider a net panel B with another net panel A upstream, as shown in Figure 39.

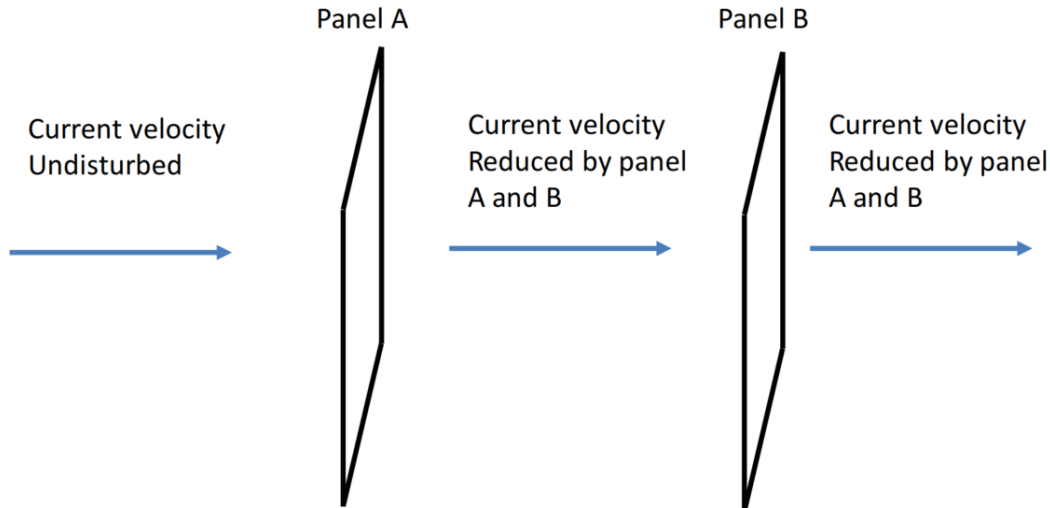

Figure 39 Current reduction on net panel

If current reduction is applied, then a reduction factor, CRF (Current Reduction Factor), for the flow behind any net is:

$$CRF = 1 - 0.46 \cdot LFC$$

Equation 60

Where:

$$LFC = 0.04 + (-0.04 + 0.33Sn_{2D} + 6.54Sn_{2D}^2 - 4.88Sn_{2D}^3)\cos(\alpha)$$

Equation 61

Where α is the angle of the net panel relative to the flow direction and Sn_{2D} is the solidity according to the (Løland, 1991). For membrane load formulation *Regular net*, the solidity is calculated according to Equation 62.

$$Sn_{2D} = \frac{d}{L_y} + \frac{d}{L_z}$$

Equation 62

Where d is the diameter of the twine, L_y is the maskwidth in local y-direction and L_z is mask width in local z-direction. When applying membrane load formulation other than *Regular net*, we have that $Sn_{2D} = 0.6$ because it is assumed that the current reduction for impermeable membranes cause the same current reduction as a net with solidity of 60%.

Now, consider the case as shown in Figure 39. The velocity behind panel A is reduced by applying Equation 60 to panel A. The reduced velocity is then applied to panel B. Behind

panel B, the current velocity is even further reduced. Downstream of panel B the current velocity is found by applying Equation 60 with the current velocity already reduced by panel A and B.

For an impermeable net, current reduction is applied with an equal reduction of all elements in the component group, such that all elements have the same current reduction as the least shielded element in the group.

5.12 Wave amplitude reduction on membrane

Wave amplitude may be reduced by a factor. Choosing 0.0, corresponds to full wave and no reduction. A value of 1.0 means full reduction and no wave, 0.5 means reduction of wave amplitude by 50%. This is useful in cases where certain objects are upstream and cause reduced wave amplitude.

5.13 Fouling/ growth on membrane

The parameter “**growth coefficient**” is a parameter to account for increased diameter of twines from fouling. Having this parameter to 1.5 means the diameter, d is increased with 50%. Fouling has the same density as water (1025 kg/m^3) and is added to the mass of the twine.

5.14 Mass density and weight

Mass density is given as separate values, both values are multiplied with the total volume of twine within an element to obtain the weight and mass of the element. The basic weight is based on the “in water” weight of the mass density given as input. This can be altered in the input. The net weight is not changed for in and out of water for cases where this option is used. This is due to the normally low weight of the net and the risk of creating non convergence. **Note (11)**.

Note (11)

For permeable nets (Type: normal) with bottom, the effect of ‘in and out of water’ is important and is accounted for.

5.15 Pretension for membrane

The definition of pretension in AquaSim is actually pre-strain. A value of 0.01 means that the twine is assumed stretched 1 % at the modeled configuration. This means that the axial force in each twine is found as:

$$N = EA(L - L0(1 - PRE))/(L0(1 - PRE))$$

Equation 63

Where:

- N is the axial force
- E is the elastic modulus of the twine
- A is the cross sectional area of the twine

- *PRE* is the pre-strain in the given direction (y- or z-direction), given as input in AquaSim
- *L0* is the initial/modelled length
- *L* is the calculated/instantaneous length

5.16 Volume

The volume inside membrane structures can be calculated to validate how much the net volume is reduced when current and waves are applied. The user must choose if the enclosed net volume has openings in the top and bottom of the modelled membrane structure.

5.17 Net in air

There is an option to have the net in air instead of in water. Choosing this, the net will be exposed to wind loads instead of wave loads. The applied wind profile is equivalent as for beam elements, see chapter 4.23.10.

5.18 Rayleigh damping

Rayleigh damping for membrane is similar as for beams and truss. For more information, reference is made to chapter 'Rayleigh damping'.

5.19 No compression forces

Choosing this option, forces in the net twines will be set to 0 if compressed in the AquaSim analysis.

6 NODE PROPERTIES

A range of properties may be assigned to nodes. The properties are described in the succeeding chapters.

6.1 Degree of freedom, DOF

Each node has 6 degrees of freedom, or DOFs. The degrees of freedom are translation along- and rotation about the global x-, y- and z-axis in an orthogonal coordinate system. By default, all DOFs are free. They may be set to fixed independently in AquaEdit.

6.2 Local coordinate system

A node can be assigned a local coordinate system. This is done by introducing 6 parameters, the (x-, y-, z-) values of the local x- and z- axis in the global coordinate system.

When a local coordinate system is introduced, the local coordinate system will rotate with the rotation of adjacent elements. This can be a necessity when analyzing e.g. hinged structures where the hinges rotate.

6.3 Pointload

There is a range of properties that can be assigned to pointloads (node load). In AquaSim, the different properties of pointloads are numbered. The different numbers decide how it is treated:

Table 4 Load types for pointloads in AquaSim

Name	Description
Conservative with mass (0)	This means a conservative node load. If the z- value of this node load is less than 0 this means the node load is interpreted as a weight, and a mass of force/gravity is introduced.
Forces from waves/ current x- (1)	This means that node loads are multiplied with $V_{xr} \cdot \text{abs}(V_{xr})$ where V_{xr} is the relative velocity between the fluid and the node. This means that for flow along the x- axis, this can be used to introduced drag, lift or moment in any direction.
Forces from waves/ current y- (2)	This means that node loads are multiplied with $V_{yr} \cdot \text{abs}(V_{yr})$ where V_{yr} is the relative velocity between the fluid and the node. This means that for flow along the y- axis, this can be used to introduced drag, lift or moment in any direction.
Forces from waves/ current z- (3)	This means that node loads are multiplied with $V_{zr} \cdot \text{abs}(V_{zr})$ where V_{zr} is the relative velocity between the fluid and the node. This means that for flow along the z- axis, this can be used to introduced drag, lift or moment in any direction.
Force from waves/ current (4)	This means that node loads are multiplied with $V_i \cdot \text{abs}(V_{tot})$ where V_i is the relative velocity between the fluid and the node in direction x-, y- and z- respectively. V_{tot} is the total velocity vector (x-, y-, z-). If the node has rotational DOFs spring stiffness values 4-6 is multiplied with velocities 1-3 respectively.
Force from waves/ current horizontal (5)	This means that node loads are multiplied with $V_i \cdot \text{abs}(V_{xy})$ where V_i is the relative velocity between the fluid and the node in direction x- and y- direction. V_{xy} is the velocity vector in the horizontal plane (x-, y-). If the node has rotational

	DOFs spring stiffness values 6 is multiplied with $abs(V_{xy}) \cdot abs(V_{xy})$. Note, this load type is implemented only for response in x-y-plane (force/moment in z-direction will give 0 response).
Drag/ lift -v1 (6)	This option introduces lift to the direction such that flow along the positive x- axis leads to force along the positive y- axis. Meaning that the imposed node load in x-direction, F_x , is found at $-V_y \cdot abs(V_{xy})$ where V_y is the relative velocity between the fluid and the node in the y- direction. V_{xy} is the velocity vector in the horizontal plane (x-, y-). F_y is found as $V_x \cdot abs(V_{xy})$ where V_x is the relative velocity between the fluid and the node in the x- direction.
Drag/ lift -v2 (7)	This option introduces lift to the direction such that flow along the positive x- axis leads to force along the negative y- axis. Meaning that the imposed node load in x-direction, F_x , is found at $V_y \cdot abs(V_{xy})$ where V_y is the relative velocity between the fluid and the node in the y- direction. V_{xy} is the velocity vector in the horizontal plane (x-, y-). F_y is found as $-V_x \cdot abs(V_{xy})$ where V_x is the relative velocity between the fluid and the node in the x- direction.
Drag/ lift -v3 (8)	Drag, lift and weight to point relative to inflow angle. The input force in x-direction (corresponding to ‘Force X’ in AquaSim) is in this case interpreted as drag force. The input force in y-direction (‘Force Y’ in AquaSim) is interpreted as lift. Hence, both drag and lift are only occurring in the horizontal plane. Load in z-direction is interpreted as normal load in z-direction.
Force and Torque from wind horizontal (9)	Introduce force and torque that is proportional with the relative velocity between the node and wind velocity in the horizontal (xy) plane. The resulting force in P is the product of the force F in x-direction and relative velocity V . For x- and y-direction one get: $P_x = F_x \cdot V_x \cdot abs(V_{xy}), P_y = F_x \cdot V_y \cdot abs(V_{xy})$ where F_x is the force input to AquaSim, $V_x = V_{wind(x)} - V_{node(x)}$ and $V_y = V_{wind(y)} - V_{node(y)}$ is the relative velocity, and $abs(V_{xy}) = \sqrt{V_x^2 + V_y^2}$ is the velocity vector in xy-plane. The resulting torque T is the product of the moment M about x-axis and relative velocity V . For x- and y-direction one get: $T_x = M_x \cdot V_x \cdot abs(V_{xy}), T_y = M_x \cdot V_y \cdot abs(V_{xy})$
Conservative no mass (100)	Is the same as 0, but no mass is introduced.

Then three values are assigned for forces:

1. Conservative nodal force x- direction [N]
2. Conservative nodal force y- direction [N]
3. Conservative nodal force z- direction [N]

and three values are assigned for moments about the axis.

4. Conservative nodal moment about x- axis [Nm] : 0.0
5. Conservative nodal moment about y- axis [Nm] : 0.0
6. Conservative nodal moment about z- axis [Nm] : 0.0

6.4 Impulseload

Impulse load is a load that acts from the very beginning of the dynamic analysis. The selected node is forced to have a given velocity at the initial step of the dynamic part of the analysis. A mass and weight may also be added at the same time step.

Care must be taken when applying this option, as it may be highly unstable. An alternative is to apply a load RAO (Response Amplitude Operator) in the time domain to apply the impulse load in a more controlled manner. Read more about RAO in chapter 6.7.

6.5 Prescribed

Nodes may be assigned a prescribed displacement or rotation. The position of a prescribed node may be defined by 'Prescribed position' in the x-, y- or z-direction. Or the user may assign a 'Prescribed rotation' which specifies rotations about the same axes. In the initial static steps of the analysis, the nodes are prescribed in linear increments.

6.6 Spring

A range of springs may be assigned to the nodes. The different types are:

Table 5 Spring types in AquaSim

Type	Description
Normal	Spring stiffness is constant throughout the analysis.
Initial	The spring gets offloaded at the initial static steps in the analysis. The spring stiffness at initial step no. n is 10% of the spring stiffness of step $n - 1$.
Dampner	Is not a spring in the classical meaning of the word. But is an object that have a force proportional to the velocity of the node.
Mass	Is not a spring in the classical meaning of the word. But is an object that have a force proportional to the acceleration of the node.
Buoy	The spring attached to the water line like a buoy. This imply that the vertical spring force is linear with respect to the water line. Stiffness in other directions is like a normal spring.
Offloaded	The spring works like a normal spring in the initial static steps. Then the spring is offloaded when the dynamic part starts. It can typically be used to find equilibrium for structures which move freely.

Offloaded2	Scales downward in the same manner as initial spring but scales down over 2 times the initial steps. This means there is some effect of this in the start of the dynamic analysis.
Displaced (Bottom spring)	<p>The spring is nonlinear to a bottom point below the node. The spring defines the location of the bottom spring relative to the node. Both stiffness and damping can be added. The relation between stiffness and force is:</p> $F_z = k_z \cdot r_{z(rel)}^5$ <p>where F_z is the bottom force, k_z is the stiffness and $r_{z(rel)}$ is the relative vertical displacement between the node and the reference bottom point. For x- and y-direction we have:</p> $F_x = k_x \cdot 5 \cdot r_{z(rel)}^4 \cdot r_x$ $F_y = k_y \cdot 5 \cdot r_{z(rel)}^4 \cdot r_y$ <p>r_x and r_y is the displacement of the node in x- and y-direction. Damping can be interpreted as a force that is proportional with the velocity of the node:</p> $F = k \cdot \dot{r} \cdot C$ <p>Where \dot{r} is the node velocity, $C = (RX, RY, RZ)$ is the damping input to AquaSim.</p>

6.7 RAO

RAO (Response Amplitude Operator) are statistics used for determining the probable behavior of an object at sea. It is widely used in ship design to determine how the ship will behave under influence of current, wind and waves.

AquaSim apply several RAOs:

- RAO on nodes
- RAO on Pointloads
- RAO on Spring

6.7.1 RAO on nodes

In AquaSim, RAO can be applied to nodes by assigning a specific translation or rotation. It may be activated in one or more DOFs independently.

‘Fixed translation’ gives the x-, y- and z- translation where the end point becomes the origin point for the RAO motion. ‘Prescribed rotation’ specifies rotations about the same axis. In the initial steps the nodes are prescribed in linear increments.

‘Position of RAO data’ defines the point of origin of the RAO data. If $(x, y, z) = (0, 0, 0)$, the RAO data will have its source in the origin of the global coordinate system, regardless of the position of the RAO-node. The outcome of the RAO will still occur in the selected RAO-node. If the user wishes to have the RAO data in the same position of the RAO-node, simply type the coordinates of the RAO-node.

RAO table

The overall response of the node will be affected by the incoming wave. That is, the node will displace (or rotate) with a defined amplitude with respect to the wave. To establish a relation between the response amplitude and incoming wave, one must establish a RAO table.

RAO type

The type defines what the amplitude of the RAO should be depended on. In AquaSim, one can define the response amplitude with respect to wave frequency (WF), hertz (Hz) or wave period (WP). In addition, the RAO can also be time-dependent.

In AquaSim, the amplitude of the response is generally expressed as:

$$r = Amp \cdot \zeta_A \sin(\omega t - kx)$$

Equation 64

where r is the response, Amp is the amplitude of the response (this is the input to AquaSim), $\zeta_A \sin(\omega t + kx)$ is the wave elevation. If ‘Fixed translation’ is defined, then the response is expressed as:

$$r = R + Amp \cdot \zeta_A \sin(\omega t - kx)$$

Equation 65

where R is the fixed translation.

The RAO type hertz (Hz) is expressed in terms of $1/T$, where T being the wave period.

When the response amplitude is defined as a function of time, the response is not proportional to the incoming wave, but at specified time instants.

6.7.2 RAO on Pointload

RAO may be assigned to a Pointload. Then the values 1-6 described in chapter 6.3 are dummies, and the loads are determined by the RAO instead. A “dummy” is a variable, or categorical effect, that is not taken into account in the AquaSim analysis. Choose between two types of RAO:

1. Normal: RAO in terms of force or moment that is proportional to the incoming wave, or time.
2. Drift polar: RAO in terms of a drift-coefficient in polar coordinates. This is a 2nd order slow drift RAO.
3. Drift cartesian: RAO in terms of a drift-coefficient in cartesian coordinates. This is a 2nd order slow drift RAO.

RAO Type: Normal

This RAO type provides access to the same RAO-tables as described in section 6.7.1. Only here the amplitude of the RAO is force and moment.

RAO Type: Drift cartesian and Drift polar

This is a type of RAO to account for slow-drift excitation loads. Slow-drift excitation loads are forces due to non-linear interaction effects between waves and the object motions. For irregular sea, the 2nd order slow-drift force is calculated as (see (Faltinsen, 1990) Eq. 5.44):

$$F_i^{SV} = 2 \left(\sum_{j=1}^N A_j (T_{jj}^{ic})^{1/2} \cos(\omega_j t + \epsilon_j) \right)^2 \quad [N]$$

Equation 66

where A_j is the wave amplitude of the j -th sinusoidal wave in the irregular sea description, \sqrt{T} is drift coefficient for the wave period, and ϵ is a random phase angle. \sqrt{T} is the input to the RAO table in AquaSim. Further, $i = [1, 2, 3]$ are respectively x-, y-, and z-component of the slow-drift force.

For regular waves the slow-drift force can be reduced to:

$$F^{SV} = 2 \cdot \left(A^2 (\sqrt{T})^2 \cdot \frac{1}{2} \right) = A^2 (\sqrt{T})^2 \quad [N]$$

Equation 67

6.7.3 RAO on Spring

RAO may be assigned to a Spring with type Normal. Available RAO type is Time. The same principles as RAO on Pointload applies, only here an amplitude of translatory spring stiffness or rotational stiffness is given as input.

6.8 Roller

Rollers may be introduced in AquaSim. A roller is typically used for ropes to slide along other ropes, or to attach a rope sliding through other parts. This is shown in Figure 40 where rope C can slide along rope AB (rope A and B is one rope going through the roller at point P).

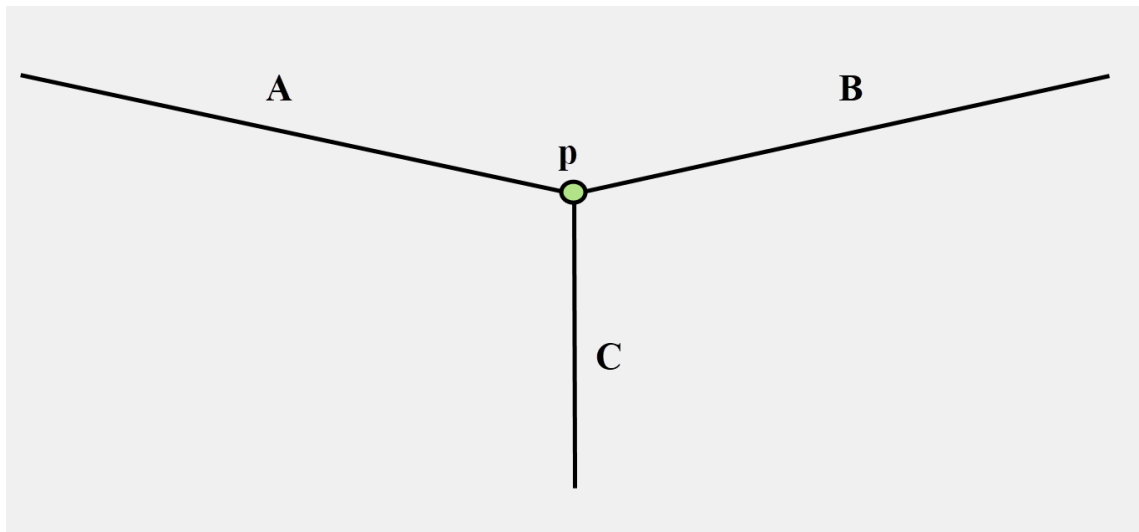

Figure 40 Point P is a point where rope C slides along rope AB. Rope c is a necessity, because roller P must be attached to more than rope A and B to be of valid use

Elements are chosen on each side of the roller. When the analysis is run the axial forces in element A and B are compared and the time step will not converge until the forces are within the “Tolerance” of the defined “Delta force”. If the “Delta force” is 0, the difference in axial force in element A and B need to be lower than the “Tolerance”. “Delta force” may be assigned positive and negative values: positive values mean element A gets higher force, negative values mean element B gets higher force.

The minimum length of element A and B respectively gives the minimally tolerated length on one side of each element. This means that if the roller slides towards the end on the cable where the roller is, it will stop at this minimum length. Stepping factor and decrease stepping are factors regulating numerical parameters for the iterations on roller placement. They can be accelerated from the default, but that enhance the risk of divergence.

7 ELEMENT PROPERTIES: NODE2NODE

The component type Node2node is a spring and one can choose between the types Node to node spring and Node to node damping.

7.1 Node to node spring

This is a regular spring which may be defined as linear or nonlinear (which is equivalent as for beam and truss). If the springs are linear the force is found by:

$$F_i = k_i r_i$$

Equation 68

where k is the spring stiffness, $r = r_{node2} - r_{node1}$. r_i is the translation along the respective axis ($i = 1, 2, 3$ corresponding to x, y, z direction, and $i = 4, 5, 6$ corresponds to respective rotations). Input to AquaSim is given as 3 linear stiffness components for translations and 3 linear stiffness components for rotations. Alternatively, the springs can be assigned nonlinear properties. Nonlinear data (NLD) is defined in a table where the user may input displacement, force, rotation, or moments for selected directions in the x-, y- and z-direction.

7.2 Node to node damping

This is damping where the force is proportional to with the velocity of the node. The spring force is found as:

$$F_i = c_i \cdot \dot{r}_i [N]$$

Equation 69

where

- c_i is the damping coefficient (this is the input to AquaSim)
- $\dot{r} = \dot{r}_{node2} - \dot{r}_{node1}$ is the node velocity.

Applying Node to node damping, effect (watt) can be reported for both translation and rotation. The translatory effect due to spring force and node velocity is:

$$W_i = F_i \cdot \dot{r}_i \left[\frac{Ns}{m} \right]$$

Equation 70

where

- $i = [1,2,3]$ which correspond to x-, y- and z-direction,
- W_i is effect (watt),

Rotational effect due to spring moment and node angular velocity is expressed as:

$$W_i = M_i \cdot \dot{r}_i \left[Nm \frac{rad}{s} \right]$$

where

- $i = [4,5,6]$ which corresponds to about x-, y- and z-axis,
- W_i is effect (watt),
- M_i is the spring moment.

8 NONLINEAR MATERIAL BEHAVIOR

Nonlinear relation between applied forces and structural response can be assigned to beams, truss and node2node springs. Internal forces due to nonlinear material behavior are calculated by AquaSim as:

- Nonlinear node2node spring where relation between displacement and force is given as input.
- Nonlinear axial force for truss elements.
- Nonlinear bending resistance in beams.

9 LOADS

There are different types of loads. The load may be characterized by how the elements and nodes respond to various load effects and overall loads such as current, wind and waves.

9.1 Static load

Static load and load effects can be introduced to AquaSim in several ways. The static load obtains a realistic condition for the system when there is no environmental action. It can be considered as a starting point for an analysis:

- Weight: the weight of a component in air.
- Buoyancy: the displacement of water caused by the element. Buoyancy results in an upwards force.
- Pretension: a part of the static equilibrium. The results from the static equilibrium based on having defined pre-strain in each element in the system.
- Hydrostatic pressure: the pressure caused by the water surrounding an object. The integration of hydrostatic pressure around an object gives the buoyancy.
- Conservative node loads: these are independent of time.

9.2 Environmental loads

This chapter describes the environmental loads wind, waves and current, which may be included in AquaSim. Note that waves and current are introduced by incrementation as shown in Figure 43.

9.2.1 Waves

In AquaSim, one may introduce regular- or irregular waves. This section presents the input parameters for waves such as amplitude (A), significant wave height (H_s) and zero mean crossing period (T_z). Mean zero crossing period of the wave spectrum, number of sinusoidal waves used to present an irregular wave, as well as the random number seed determines the initial phase of each wave components. The theory used for waves in AquaSim is validated in (Aquastructures, 2019b).

Regular waves

Assuming infinite water depth, linear Airy wave theory is applied where the wave potential ϕ_I can be expressed as:

$$\phi_I = \frac{g\zeta_a}{\omega_0} \cos(\omega t - kx\cos\beta - kysin\beta)$$

Equation 71

for a sinusoidal wave, where ζ_a is the wave elevation amplitude, ω_0 is the wave frequency, k is the wave number, g is the acceleration due to gravity, and β is the wave heading relative to the global x-axis. ϕ_I is the wave potential due to the incident waves (see e.g. (Faltinsen, 1990)). The wave elevation is then described as:

$$\zeta = \zeta_a \sin(\omega t - kx\cos\beta - kysin\beta)$$

Equation 72

Or, by letting $\zeta_a = A_n$:

$$\zeta = A_n \sin(\omega t - kx\cos\beta - kysin\beta)$$

Equation 73

where A_n is the wave amplitude. For finite water depth, the wave potential is adjusted to account for this:

$$\phi_I = \frac{g\zeta_a \cosh k(z+h)}{\omega_0 \cosh kh} \cos(\omega t - kx\cos\beta - kysin\beta)$$

Equation 74

The wave elevation is then:

$$\zeta_a \frac{\cosh k(z+h)}{\cosh kh} \cos(\omega t - kx\cos\beta - kysin\beta)$$

Equation 75

k is the wave number and related to ω . For infinite water depth the relation is:

$$\frac{\omega^2}{g} = k$$

Equation 76

For finite water depth the relation between k and ω is:

$$\frac{\omega^2}{g} = k \tanh kh$$

Equation 77

Irregular waves

Irregular waves are defined by a spectrum where the energy is divided over several wave components. Then the energy is discretized to a finite number of sinusoidal waves. The wave elevation is described as:

$$\zeta = \sum_{n=1}^N A_n \sin(\omega_n t - k_n x \cos \beta_n - k_n y \sin \beta_n + \varepsilon_n)$$

Equation 78

Where ε_n is a random number equally distributed between 0 and 2π . A_n is the wave amplitude of the n th wave component found as:

$$\frac{1}{2} A_n^2 = S(\omega) \Delta \omega$$

Equation 79

where $S(\omega)$ is the spectral value. Wave spectra have characteristic values describing how $S(\omega)$ varies with ω . An example of this is:

$$S(\omega) = K_1 \omega^{-5} \exp(-K_2 \omega^{-4})$$

Equation 80

where

$$K_1 = \frac{\omega_z^4 H_s^2}{4\pi} \text{ and } K_2 = \frac{\omega_z^4}{\pi}$$

Which corresponds to Pierson-Moskowitz spectrum. This is one of the spectra which can be applied in the AquaSim wave generator.

Most commonly, the parameter H_s is defined as follow:

$$H_s = 4\sqrt{m_0} = 4\sigma$$

Equation 81

where m is the moment in the wave spectra, and:

$$\int_0^{\infty} S(\omega)d\omega = \sigma^2$$

Equation 82

where σ is the standard deviation of a stochastic process. Combining Equation 79 and Equation 82, it is seen that for all irregular wave patterns which are composed by a sum of sinusoidal waves, the standard deviation of the time series consisting of N wave components can be found as:

$$\sigma^2 = \sum_{i=1}^N \frac{A_i^2}{2}$$

Equation 83

Introducing this to Equation 81, H_s is found ‘backwards’:

$$H_s = 4 \sqrt{\sum_{i=1}^N \frac{A_i^2}{2}}$$

Equation 84

This can be used as self-check to ensure that any manually built wave introduced to AquaSim have the desired H_s .

Wave spectra

There exist a range of spectra and formulations to the parameters H_s and T_z . Following (Faltinsen, 1990), some of these can be used in AquaSim. Irregular waves derived from spectra can be utilized in AquaSim. Using the wave generator in AquaSim, one shall not only introduce H_s , but also T_z or $\omega_z = 2\pi/T_z$. We define:

$$T_1 = 2\pi m_0/m_1$$

Equation 85

where

$$m_k = \int_0^{\infty} \omega^k S(\omega)d\omega$$

Equation 86

which is a commonly used definition for T_z . Further:

$$T_z = 2\pi\sqrt{m_0/m_2}$$

is another definition of mean zero crossing period and often associated with the PM (Pierson-Moskowitz) spectrum. What the 'correct' value of T_z is, depend on how the spectral formulations are defined in consistency with the mean zero crossing period. Both T_1 and T_2 are definitions of T_z . T_1 is often used with JONSWAP spectra whereas T_2 is most common together with PM spectra formulations.

Another commonly used parameter associated with spectra is T_p , which is the peak period of the wave spectra. For a PM spectrum, this period is approximately $1.41 \cdot T_2 = 1.3 \cdot T_1$.

PM spectrum

The Pierson-Moskowitz spectrum is a one-parameter spectrum, with the wind velocity as the parameter. This spectrum is based on data from the North Atlantic. It assumes a fully developed sea. The formulation of the spectrum in AquaSim is:

$$S(\omega) = \frac{A}{\omega^5} e^{\frac{-B}{\omega^4}}, B = \frac{\omega_0^4}{\pi}, A = B \frac{H_s^2}{4}, \omega_0 = \frac{2\pi}{T_z}$$

Equation 87

In general, $T_z = T_2$ for the PM spectrum formulation.

JONSWAP spectrum

The Joint North Sea Wave Project (JONSWAP) is a result of a multinational measurement project in the south-eastern part of the North Sea. It assumes the wave spectrum is never fully developed. The formulation of the spectrum in AquaSim is:

$$S(\omega) = 155 \frac{H_s^2}{T_z^4 \omega^5} e^{\left(\frac{-944}{T_z^4 \omega^4}\right) \gamma^Y}, Y = e^{-\left(\frac{0.191 \omega T_z - 1}{\sqrt{2} \sigma}\right)^2}$$

Equation 88

$$\sigma = 0.07 \text{ for } \omega \leq 5.24/T_z$$

$$\sigma = 0.09 \text{ for } \omega > 5.24/T_z$$

$\gamma = 3.3$ are the default value. $\gamma = 3.3$ corresponds to JONSWAP spectrum in (Faltinsen, 1990). In general, $T_z = T_1$ for the JONSWAP spectrum formulation.

ITTC spectrum

International Towing Tank Conference assumes fully developed sea states for open oceans. This is a modification of the PM spectrum. The formulation of the spectrum in AquaSim is:

$$S(\omega) = H_s^2 T_z \frac{0.11}{2\pi} \left(\frac{\omega T_z}{2\pi}\right)^{-5} e^{\left(-0.44 \left(\frac{\omega T_z}{2\pi}\right)^{-4}\right)}$$

Equation 89

where $T_z = T_1$.

Wave period cut off

The spectral wave generation in AquaEdit chooses a cut off value automatically. The wave energy in the lowest wave period (corresponding to the highest frequency) contains all the spectral energy in the spectrum up to infinite wave frequency. All the above spectral formulations have a decay in energy of ω^{-5} as the wave frequency increases. The integral of this decays with ω^{-4} . That means that the wave amplitudes of the generated waves will decrease with ω^{-2} if one makes the $\Delta\omega$ successively longer as ω increases. For 2nd order or other nonlinear terms, this may be a challenge if the wave amplitude does not naturally die out for high frequencies.

This can be studied in AquaSim by investigating the sinus components that have been generated from the input. All wave components are shown after waves have been generated, and one may change from specter-generated waves to general waves in case one wish to manipulate the components

Randomization of wave periods

Figure 41 illustrates how wave energy in a spectrum may be represented by a set of waves. If randomization of wave period is not chosen, the period of the generated wave will be the period in the center of the interval the wave component represents, see Figure 42.

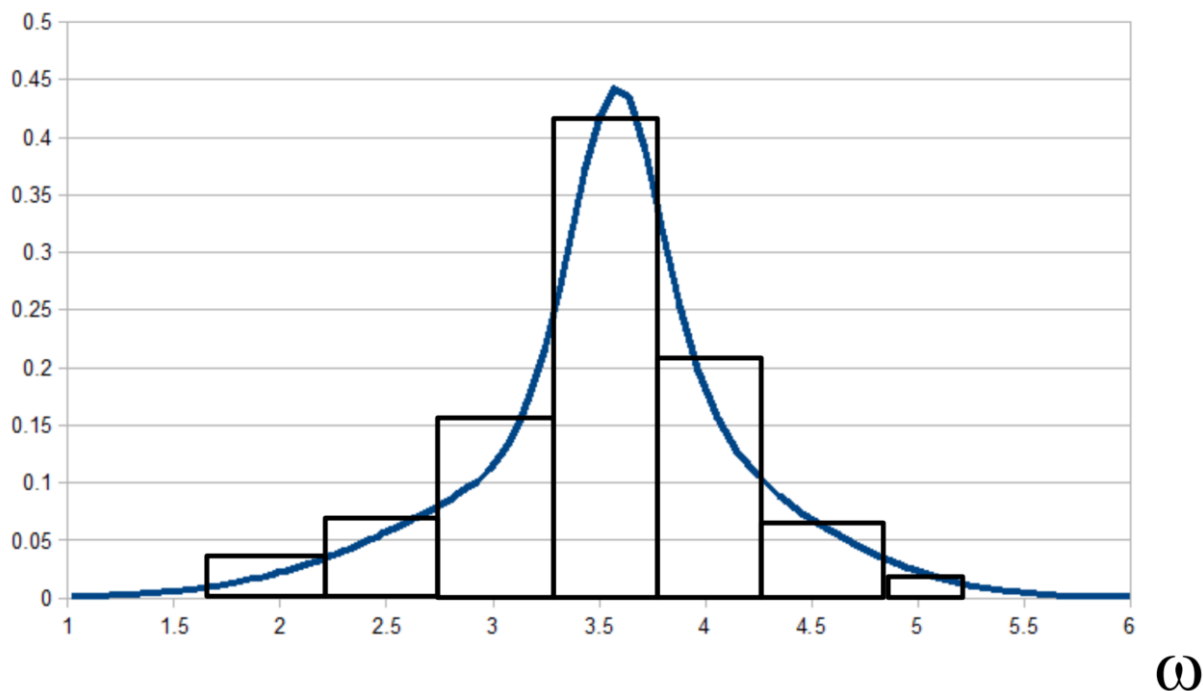

Figure 41 Discretization of wave spectrum

In Figure 42 the red arrows are placed in the center of the interval. This is where the period of the wave component is if wave periods are not randomized. If periods are randomized the wave period is placed randomly along the blue double-sided arrows for the given period range. Each interval holds an independent random number determined by the random seed.

Note (12).

Note (12)

If randomization of waves is not chosen, the patterns of the generated waves tend to repeat itself.

If randomization is chosen, self-repeating happens after longer intervals. Self-repeating can be investigated by inspection of time series of waves. Normally 100 wave components are used, it will not self-repeat until 100 waves are generated. If randomization is not chosen, the wave peaks tend to be smaller compared to randomization. The maximum wave at a specific point (x_0, y_0) can be lower in a generated time interval than the normal $1.9 \cdot H_s$ which is a commonly used value when applying a design wave. The user should investigate this to make sure that the irregular wave time series contains a large enough wave to trig maximum response.

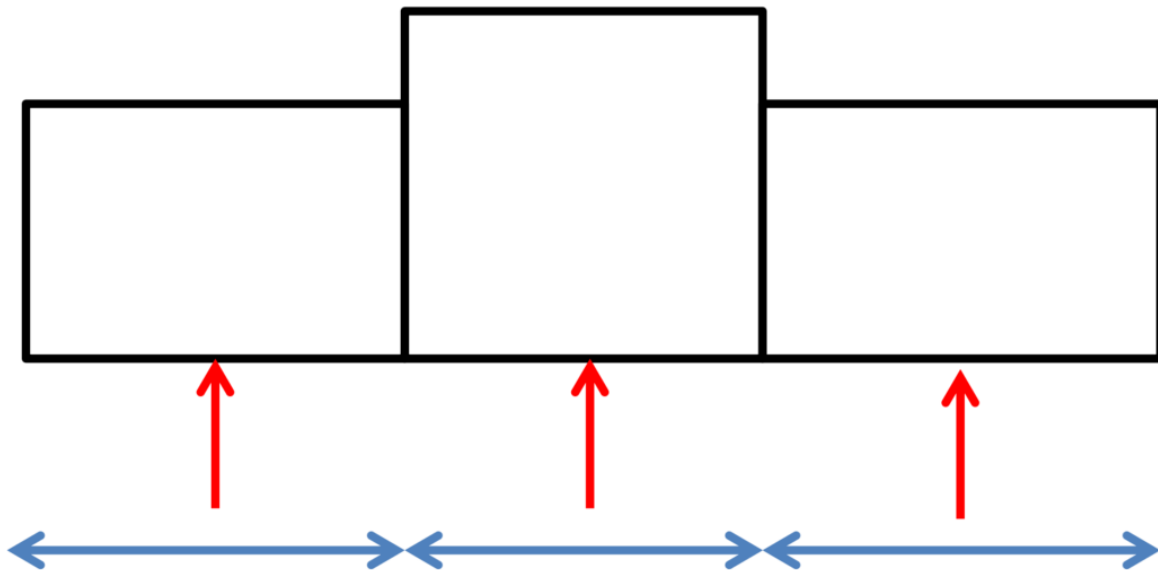

Figure 42 Center of blocks marked with red arrows. Interval marked with the blue arrows. The representative period can be chosen randomly within the interval

Short crested waves

For short crested waves, there are a randomization of the wave direction of each wave component. The direction of the wave is given by:

$$\beta_i = \cos^n \phi_i$$

Equation 90

where n is given as input by the user (2 is a commonly used value), see e.g. (Faltinsen, 1990). ϕ_i is equally randomly distributed in the interval $[-\pi/2, \pi/2]$, and i is the index of the i^{th} wave component in the time series representing the irregular waves. The direction angle β is added to the wave direction given as input to the sea state.

Short crested waves may be introduced in two ways: N is the number of wave components where each component has a randomly angle in the interval $[-\pi/2, \pi/2]$ weighted by the appropriate $\cos^n \phi$. The number of waves may also run in symmetry mode. Then each wave component with an angle within $[0, \pi/2]$ has a corresponding angle $[-\pi/2, 0]$.

9.2.2 Regular wind

Wind velocity is an input parameter to AquaSim. For wind load to be applied to a component, appropriate data for wind fetch must be specified for the component. For regular wind, the wind profile is calculated according to (Aquastructures, 2021a) Ch. 2.1.1.

9.2.3 Irregular wind and wind spectra

Spectral wind load generation can be applied from NORSOK wind spectrum formulation, where wind is applied in the same direction as the mean wind. The NORSOK formulation follow the NORSOK N003 (2016) Section 6.4 from pp. 30-32.

The wind load consists of a mean wind load and a harmonic wind component, which varies with height above water and the return period. Input to AquaSim is 10-min mean wind, 10 meters above water surface or ground. The 10-min wind and harmonic wind components may be generated based on spectral formulations, then manipulated to fit any desired formulation or measurements. Theoretical formulation and validation of wind spectra is found in (Aquastructures, 2021a).

9.2.4 Current

Uniform- or time and depth dependent current may be applied in AquaSim. Waves are assumed to ride upon the current field. Consider e.g. a moving ship: then the velocity of the ship can be modeled as current with the ship stand still/fixed.

- Uniform current is uniformly time invariant current velocity. This is default in AquaSim.
- Depth dependent current is current varying with depth. The user input the depth and the value of the current. The current velocity is interpolated between each depth.
- Time dependent current: current velocity may be linearly scaled through the first steps of the analysis. In such case, current data is given for two time steps. Values between are interpolated. **Note (13)**.

Note (13)

Note that the time the interpolation is carried out between is nominal time (before adjusting step time length for current velocity).

10 PROPERTIES FOR TIMEDOMAIN SIMULATION

AquaSim carries out time domain analysis where a systems response is found from realizations of design environmental conditions. Generally, the design sea state is a combination of the worst wave condition expected in 50 years combined and the worst currents expected every 10 years.

The goal of a time domain AquaSim analysis is to find the response in terms of forces, stresses, displacements, accelerations and more of the system exposed to a combination of several environmental loads. Among such loads are as waves, currents, wind. The static and dynamic analysis are solved numerically where loads are incremented

10.1 Incrementation of static loads

Wind and current are applied gradually during the initial part of the analysis. The number of increments used to ramp up these loads is specified by the user through “Preincrement”. During these initial steps, the current velocity (and wind velocity) is increased linearly from zero to its target value. This gradual increase ensures numerical stability and stable solution before the dynamic part of the analysis. In Figure 43, the current and wind (blue line) is ramped up over 5 initial steps. After step no. 5 the full target value of current- and wind velocity is applied through the analysis.

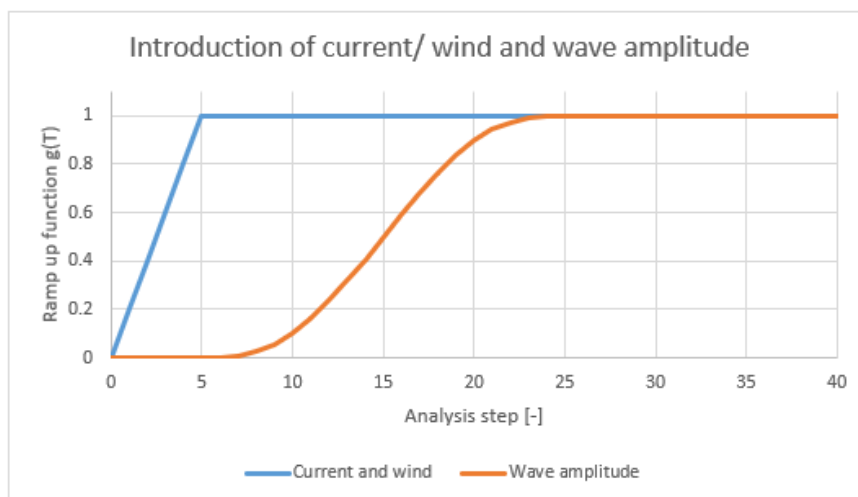

Figure 43 Introduction of current/ wind and wave amplitude as ramp up function vs. time step. Current is applied linearly over the initial steps (5 steps in this example). The dynamic part of the analysis uses 20 steps per wave period and a total of 40 time steps. Ramp up of wave amplitude is polynomial.

10.2 Preincrement, number of initial steps

This is the number of analysis steps used to increase the static loads. In AquaSim, current and wind are regarded as static loads. Current is linearly increased from 0 m/s to the input value given in the initial steps. As an example, if the current velocity in the x-direction is 1 m/s, and 3 initial steps are applied, then x-current is 0 at the first step, 0.5 m/s at the 2nd step and 1 m/s at the 3rd step.

10.3 Max iterations per step

If convergence is not obtained at this number of iterations, the analysis is stepped forward. Results may be valid even if iterations do not meet the iteration criteria. But, in general non converged results are not valid.

10.4 Incrementation of dynamic loads

After the system obtains static equilibrium, the time stepping is commenced, and time varying forces are incremented. Waves are introduced gradually during the initial phase of the dynamic analysis.

The wave amplitude (or significant wave height) is increased from zero to its target value over the first wave cycle. This increase is governed by a polynomial ramp function. The ramp function g should then satisfy:

$$g(0) = 0$$

$$g(T) = 1$$

Where T is the wave period. After the first wave cycle, the waves are applied with full amplitude for the remainder of the simulation. The ramp of wave amplitude is illustrated by the orange line in Figure 43.

10.5 Num total steps for waves

After static equilibrium is established through the initial steps, the dynamic time domain analysis commences. The input parameter giving the number of time steps in the dynamic analysis is named ‘num total steps for waves’.

10.6 Num steps for one wave

The parameter ‘num steps for one wave’ gives how many time steps for a wave cycle in a regular wave, and number of waves per average period (T_z) in case of irregular sea.

For 100 wave cycles and 20 steps per wave cycle, one must set the parameter ‘num total steps for waves’ to 2000. Note that the first wave cycle is used to build the wave amplitude, one must use 2020 steps to obtain 100 full waves.

10.7 Convergence

After the time have been incremented with Δt , both internal and external forces are calculated as shown in chapter 3.3. As the system responds in a strongly nonlinear manner, we may not necessarily achieve equilibrium, hence iterations are commencing until convergence is reached.

10.7.1 Convergence criteria

The convergence criteria in AquaSim are a combined force and displacement criteria. The convergence criteria are a $3/4$ force criteria where a force/displacement norm calculates an average over the models DOFs. The norm is given by:

$$Norm = \sum_{i=1}^N \Delta force(i)^{3/2} \cdot \Delta displacement(i)^{1/2}$$

Equation 91

where i is counted over all degrees of freedom in the system with a total of N degrees of freedom. $\Delta force$ is the difference in calculated force between the current and the previous iteration. $\Delta displacement$ is the difference in displacement between the current and the previous iteration. $Chknorm$ is found as:

$$Chk_{norm} = \frac{Norm}{N}$$

If Chk_{norm} is lower than the convergence criteria defined by the user, the solution is converged.

To ensure that the convergence criteria are detailed enough, the user should carry out analysis with refined convergence criteria. When results tend to stabilize, the convergence criteria are detailed enough, meaning the convergence criteria is sufficiently low.

10.8 Importance of time step size, response to snap loads

What is presented in this section has been published by (Berstad & Heimstad, Experience from introduction of the design code NS 9415 to the aquaculture industry in Norway and expanding the scope to cover also operations, 2017). A typical load mode for e.g. fish farm units are mooring lines and net pens going from slack to loaded condition. This causes an impact load to the rope attachment point. Impact loads caused by ropes going from unloaded to loaded are denoted ‘snap loads’. Figure 44 and Figure 45 illustrate a simplistic picture of the physics behind snap loads. **Note (14)**.

Note (14)

Note that in real fish farms the response causing ‘snap loads’ are more complex with many system degrees of freedom. However, the basic physics are the same.

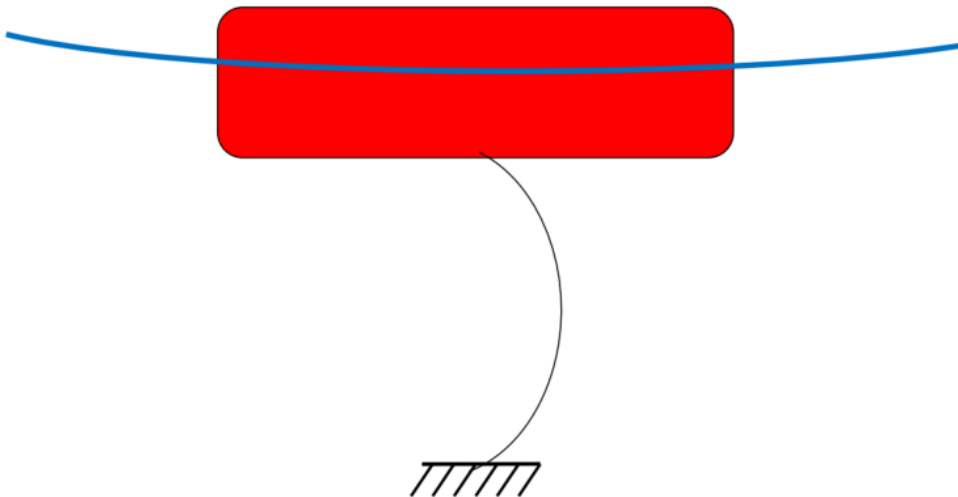

Figure 44 Float with slack rope

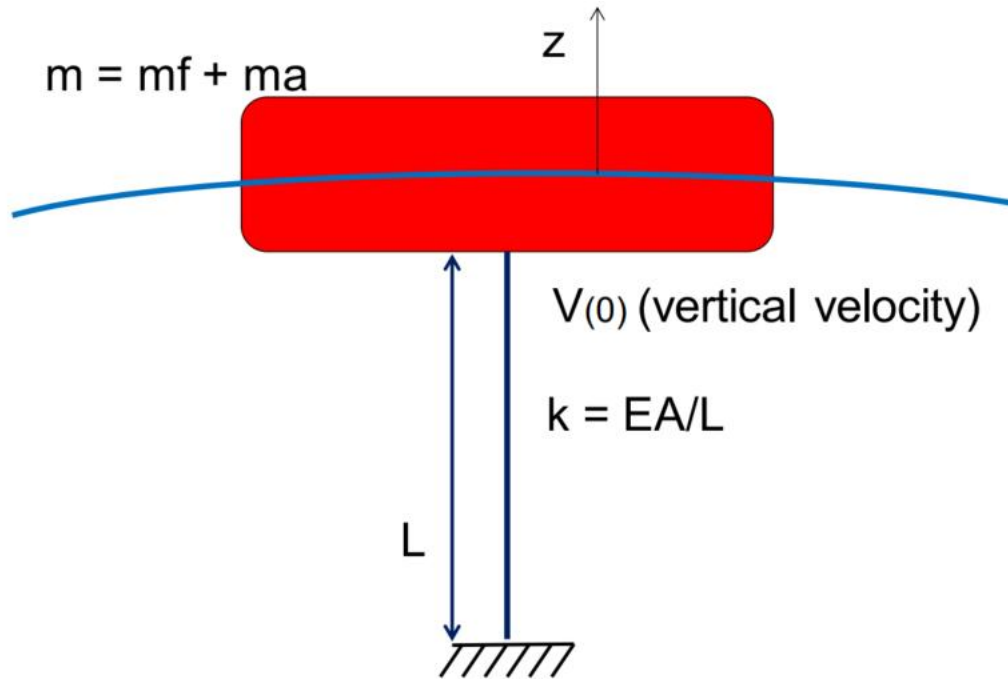

Figure 45 Initial value condition at moment rope goes stiff

m is the mass + added mass of the floater, and k is the stiffness being activated at the moment the floater rope goes from slack to tensioned. Neglecting the damping, the system can be solved by applying the classic impulse response equation for the motion:

$$z(t) = a \sin(\omega t)$$

Equation 92

where $\omega^2 = k/m$ and a is the amplitude of the impulse response. m is the mass, and k is the stiffness of the system caused by the rope holding the float back like a spring; $k = EA/L$. This is a linear solution where the stiffness and mass are assumed to be constant. Note that the water plane stiffness is neglected. The velocity is the time derivative of the displacement, and is expressed as follows:

$$\dot{z}(t) = a\omega \cos(\omega t)$$

Equation 93

where $\dot{z}(t)$ is the vertical velocity of the system. In our case, we have an initial velocity v_0 in the z -direction which is the velocity at the initial time ($t = 0$ exactly when the rope becomes stiff), expressed as:

$$v_0 = a\omega \cos(\omega t_{t=0}) = a\omega$$

Equation 94

This means the amplitude of the impulse response a is found as:

$$a = \frac{v_0}{\omega}$$

Equation 95

Now the relation between eigen period, mass and stiffness is introduced ($\omega^2 = k/m$) to the equation above:

$$a = \frac{v_0}{\omega} = \frac{v_0}{(k/m)^{1/2}} = v_0 \left(\frac{m}{k}\right)^{1/2}$$

Equation 96

This means that an impact as described above will introduce a harmonic impact response with amplitude a shown in the equation above. From the maximum response amplitude, the maximum force can be derived as:

$$F_{max} = ka = kv_0 \sqrt{\frac{m}{k}} = v_0 \sqrt{mk}$$

Equation 97

This means the maximum force is proportional to the initial velocity and the square root of the mass and stiffness. This is further described and validated in Aquastructures (2013). Before $t = 0$, assume that the velocity of the float follows the vertical velocity of the wave elevation as the wave builds up. Then v_0 can be found from the velocity of the vertical wave elevation at the moment the rope snaps. Assume a regular wave with amplitude η . The wave elevation can according to Airy wave theory (e.g. (Faltinsen, 1990) section 2) be expressed as:

$$\xi = \eta \sin(\omega_e t)$$

Equation 98

where ω_e is the wave frequency of encounter for the wave. This frequency has nothing to do with the eigenfrequency of the rope and float. At the time step $t = 0$ we get:

$$v_0 = \eta \omega_e \cos(\omega_e t_{t=0}) = \eta \omega_e$$

Equation 99

Introducing $v_0 = \eta \omega_e$, the maximum force F_{max} can be expressed as:

$$F_{max} = \eta \omega_e \sqrt{mk}$$

Equation 100

The above equations explain the susceptibility of short stiff mooring lines to mass objects, such as barges, since k is proportional to the rope stiffness and inversely proportional to the length. As seen by the above equation, shortening a rope by 1/100 will increase stiffness 100 times. Also using a chain with Elastic modulus of 10E+11 will introduce ten times the load as a rope with elastic modulus of 10E+09, given otherwise equal response. Figure 46 shows max peak loads for the case seen in Figure 44 and Figure 45 calculated from analytical formulae and AquaSim analysis. As seen from this graph, the results compare well.

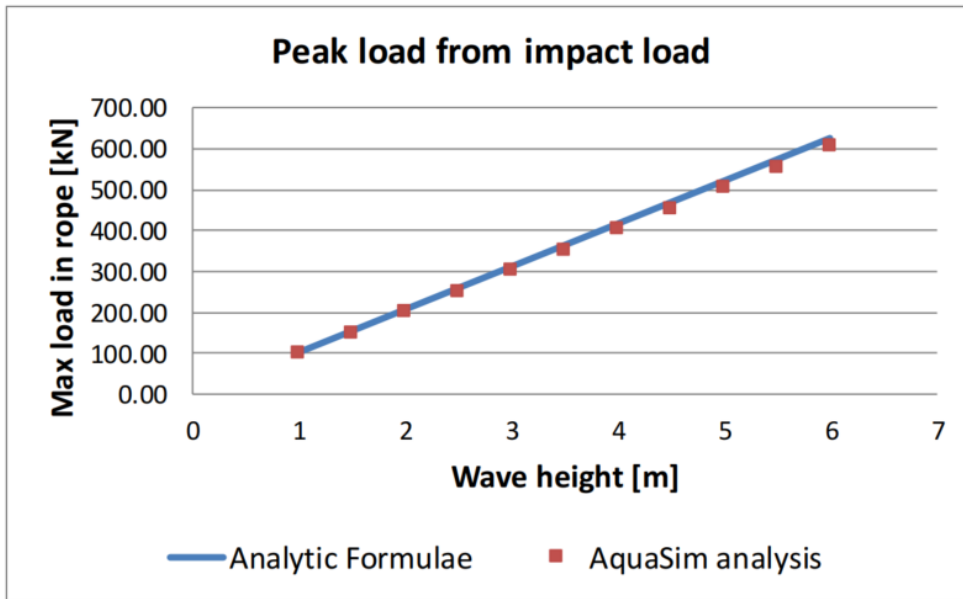

Figure 46 Response by analytical formulae to AquaSim analysis

From AquaSim analysis one can also obtain results for the response subsequent of the first impact. This is seen in Figure 47, which shows the response of the axial load in the rope as a function of time.

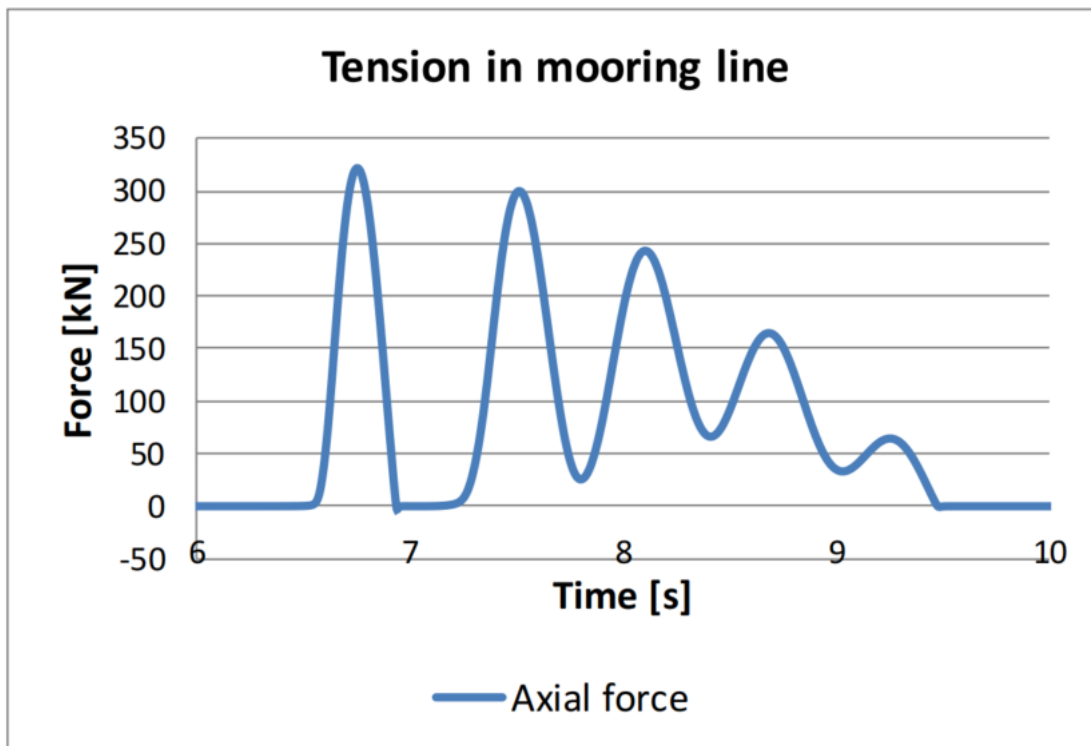

Figure 47 Tension in rope as a function of time

In Figure 47, the first response peak is the highest caused by the snapping of the rope. After maximum response, the rope is offloaded to the point where it is slack again. This strongly influences the stiffness of the system such that the system will not have a linear impulse response. This is further described in (AquaStructures, 2019a). Note that to capture such rapid response one need to have sufficiently small time increments in the numerical

calculation of response. This system is underdamped and is neglectable for the maximum response. However, it influences how fast the succeeding response decay.

For real life fish farming systems, elasticity of moorings is often assured with “geometric stiffness”, which means flexibility is obtained by geometrical changes to loads. This flexibility is equivalent to reducing stiffness by other means such as reducing the elastic modulus and/or increasing the length of the mooring lines. Normally the geometric flexibility is obtained by using chains close to the bottom and having buoys located in the mooring system between the net pen and the bottom attachment point of the mooring line.

10.9 Current reduction type

Describes how current and waves are reduced due to upstream membrane elements. AquaSim provides four different reduction types:

Current reduction type	Description
No reduction	The current velocity is not reduced behind net panels.
From initial shape	The formula for current reduction is applied to the initial configuration of the net panel.
Deformed by current	The reduction factor is found from the initial configuration and updated for the deformed configuration at step number N-1. Where N being number of initial steps (“Preincrement”).
Deformed by current and waves	The reduction of current velocity is calculated at all steps and updated. It applies a reduction factor based on configuration from step N-1.

The theory for reduction on current velocity to succeeding membranes is described in chapter 5.11 and in (Aquastructures, 2024c).

10.10 Infinite depth

AquaSim apply wave theory for finite water depth. The user may change this by choosing the ‘Infinite water depth’ option, and wave theory for infinite water depth is introduced (also referred to as Airy wave theory). This is further described in chapter Regular waves.

10.11 Cresting Wave Factor

The Cresting Wave Factor is a factor for including nonlinear wave kinematics above the mean water line. Linear wave theory (Airy wave theory) is mathematically correct only for incremental wave steepness, meaning that the crest is significantly lower than the wavelength. In AquaSim, consistent with Airy wave theory, it is assumed that the horizontal- and vertical fluid particle velocity above the mean water line is the same as at the mean water line.

Empirical data show that the steeper the wave gets to a critical level of $H/\lambda=1/7$, the higher the horizontal fluid particle velocity becomes relative to what is predicted with linear wave theory. H is the wave height and λ is the wavelength. The Cresting Wave factor accounts for increased horizontal fluid particle velocity above the mean water line for breaking waves. For linear wave theory, the horizontal fluid particle velocity at the mean water line is:

$$u = \omega \zeta_A e^{kz} \sin(\omega t - kx)$$

Equation 101

Based on the input wave height (H) and wave period (T) to AquaSim, you will get a certain wave steepness. Applying the Cresting Wave factor, the horizontal fluid particle velocity at the top of the wave crest becomes:

$$u_{NL} = u \cdot \kappa$$

Equation 102

where u_{NL} is the nonlinear horizontal component of the fluid particle velocity, κ is the input value (Cresting Wave Factor) in AquaSim. Between the mean water line and top of the crest, AquaSim will interpolate κ . This is illustrated in the figure below.

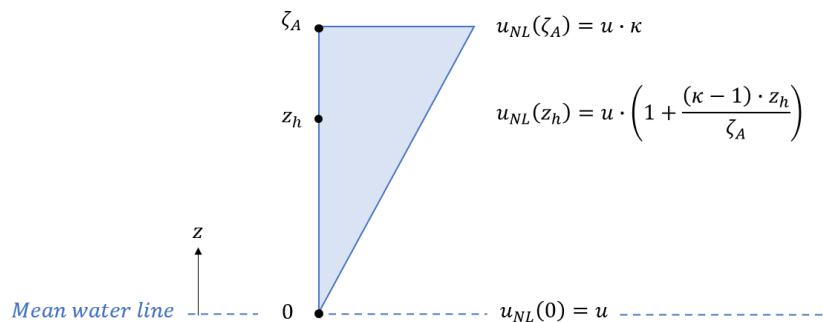

Figure 48

More theoretical background and validation are found in (Aquastructures, 2022a).

10.12 Depth (wave profile)

If the option ‘Infinite depth’ is not selected, AquaSim will apply wave theory for finite water depth. ‘Depth (wave profile)’ regulates how the water particle velocity decay down from the free water surface. See e.g. (Faltinsen, 1990) Table 2.1 for wave theory for finite water depth.

10.13 Bottom contact

In addition to introduce bottom springs to individual nodes at individual steps, the user may apply a flat bottom. The ‘Bottom contact’-option activates a flat bottom, or a seabed. The bottom then acts as a spring with a spring stiffness. The user must define the water depth, a spring stiffness and a frictional constant for the seabed.

10.14 Bottom depth

The ‘Bottom depth’ defines the distance between the still water level (at $z = 0m$) and down to the seabed. The input value should be negative and is given in meters.

10.15 Bottom parameter

This parameter is the spring stiffness of the seabed. When nodes move beneath the value defined in ‘Bottom depth’, the spring stiffness increases.

10.16 Bottom friction

The user may also define a seabed friction. ‘Bottom friction’ is linear, and the input is a number from 0 or higher. Applying a value of 0 is generally not recommended. The user should start with a simple model first, to test what value is appropriate to apply.

10.17 Dynamic vertical friction

This parameter is damping in z-direction and is proportional with the velocity of the nodes that are in contact with the seabed. As an example, it can regulate how much an object bounce on the seabed, as illustrated in the figure below. The larger this value, the more damping is introduced.

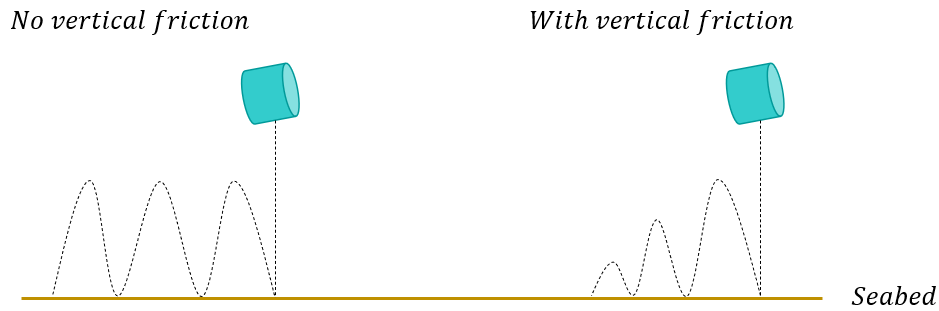

Figure 49 Dynamic vertical friction

10.18 Dynamic horizontal friction

This is damping in horizontal direction (x - and y -direction) and is proportional with the velocity of the nodes that are in contact with the seabed. Bottom contact is based on a spring with a spring stiffness. As long as the horizontal force exerted on an object at the seabed is larger than the frictional force, the object will slide. But when the horizontal force is reduced, the seabed-spring will pull the object back towards its initial impact position. To reduce this effect, Dynamic horizontal friction can be applied. The larger this value, the more damping is introduced.

10.19 Water volume correction

Water volume correction describes how the volume is corrected and corresponding forces are treated when a beam element moves in and out of water. Choose between None, Normal and With slamming.

10.19.1 None

If 'None' is chosen, AquaSim does not perform any correction of the submerged volume for hydrodynamic elements. The buoyancy is constant throughout the analysis, and the user must input the correct buoyancy depending on where the element is located in the waterline.

10.19.2 With slamming

In order to account for 'in and out of water' and slamming for beams and trusses with the Morison load formulation, the user should choose the option 'With slamming'. In this case, all elements should be modeled with the properties they have when submerged in water. In case elements are above the instantaneous water surface, AquaSim adjusts properties by removing added mass and drag from water. In addition, weight is added as the buoyancy does not work above the water surface. When entering the water, the slamming formulation is used to determine the loads. The theory of water entry and exit is further described in chapter 10.20 and (AquaStructures, 2019a).

10.20 Water entry and exit

For time domain simulation in AquaSim, one may account for object moving in and out of water and the slamming effect when an object penetrates water. In order to account for this one must choose "with slamming" when choosing "water volume correction". Doing so, beams and trusses with the Morison load formulation will be exposed to slamming loads as they enter water and buoyancy will be calculated accurately based on the part of the beam or truss being submerged. In this analysis mode beams and trusses should be modeled as if they were in water. For elements above the instantaneous water surface, AquaSim adjusts properties by removing added mass and drag from water and adds weight due to loss of

buoyancy. When entering water, the slamming formulation outlined in (AquaStructures, 2019a) is used to determine loads. **Note (15)**.

Note (15)

Water entry with slamming only applies to components where the Morison load formulation is selected.

Water entry is defined as the period where a structural member enters the water from dry condition. This is shown in Figure 50.

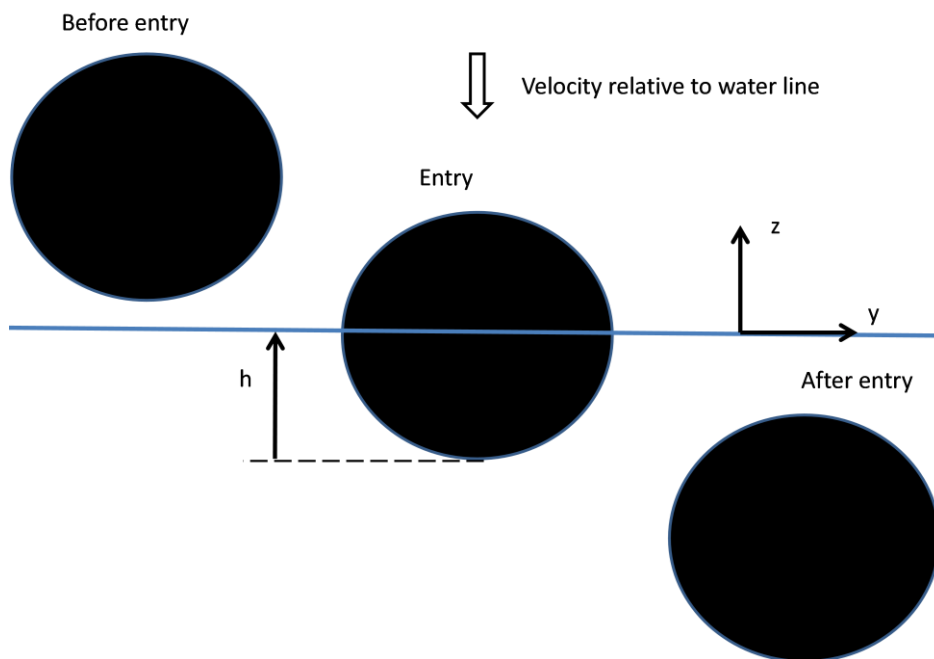

Figure 50 Water entry of circular cylinder. A cross section is seen

10.20.1 Water entry

Define an orthonormal coordinate system where the x- axis is along the cylinder in the horizontal plane, the z- axis is upwards pointing with origin at the mean water line as shown in Figure 50. For a body subjected to vertical force only, the force can be written as (see e.g. (Faltinsen, 1990) pp. 306):

$$F_3 = \rho\Omega(t) \frac{dw}{dt} + \rho g\Omega(t) - \frac{d}{dt} \left(A_{33} \left(\frac{d\eta_3}{dt} - w \right) \right)$$

Equation 103

where w is the vertical velocity of the water at the considered time instant, $w = \omega\zeta_a \sin(\omega t - kx)$ for the case of a sinusoidal wave traveling along the positive x-axis. Further we have:

- ζ_a is the wave amplitude
- ω is the wave frequency

- η_3 is the vertical location of the object penetrating the water
- ρ is the density of water
- g is the acceleration of gravity
- $\Omega(t)$ is the displaced volume at the given time instant
- A_{33} is the added mass in the vertical direction

Equation 103 can be reformulated to:

$$F_3 = \rho\Omega(t) \frac{dw}{dt} + \rho g\Omega(t) - \frac{dA_{33}}{dt} \left(\frac{d\eta_3}{dt} - w \right) - A_{33} \frac{d}{dt} \left(\frac{d\eta_3}{dt} - w \right)$$

Equation 104

Equation 104 can be expressed as:

$$F_3 = \rho\Omega(t) \frac{dw}{dt} + \rho g\Omega(t) - \frac{dA_{33}}{dt} \frac{dh}{dt} \left(\frac{d\eta_3}{dt} - w \right) - A_{33}(t) \frac{d^2\eta_3}{dt^2} + A_{33}(t) \frac{dw}{dt}$$

Equation 105

Inserting $\frac{dA_{33}}{dt} = \frac{dA_{33}}{dh} \frac{dh}{dt}$ where h is the distance from the bottom of the water entering object to the instant position as shown in Figure 50. This means F_3 can be expressed as:

$$F_3 = \rho\Omega(t) \frac{dw}{dt} + \rho g\Omega(t) - \frac{dA_{33}}{dh} \frac{dh}{dt} \left(\frac{d\eta_3}{dt} - w \right) - A_{33}(t) \frac{d^2\eta_3}{dt^2} + A_{33}(t) \frac{dw}{dt}$$

Equation 106

$\frac{dh}{dt}$ can be expressed as $\frac{dh}{dt} = w - \frac{d\eta_3}{dt}$, meaning:

$$F_3 = \rho\Omega(t) \frac{dw}{dt} + \rho g\Omega(t) + \frac{dA_{33}}{dh} \left(\frac{d\eta_3}{dt} - w \right)^2 - A_{33} \frac{d^2\eta_3}{dt^2} + A_{33} \frac{dw}{dt}$$

Equation 107

$\left(\frac{d\eta_3}{dt} - w\right)$ is the relative velocity between the object and the water, denoted v_{rel} . $v_{rel} = \frac{d\eta_3}{dt} - w$. Applying this denotation, we get:

$$F_3 = \rho\Omega(t)\frac{dw}{dt} + \rho g\Omega(t) + \frac{dA_{33}}{dh}(v_{rel})^2 - A_{33}\frac{d^2\eta_3}{dt^2} + A_{33}\frac{dw}{dt}$$

Equation 108

Equation 108 consists of five load terms, which is described below:

$\rho\Omega(t)\frac{dw}{dt}$ is the Froude-Kriloff force. This term is added not only in the z-direction, but in the horizontal plane as well.

$\rho g\Omega(t)$ is the hydrostatic force (buoyancy) which acts along the positive z-axis only.

$\frac{dA_{33}}{dh}(v_{rel})^2$ is the slamming force, see also section The ‘drag’ term in Morison equation for more details.

$A_{33}\frac{d^2\eta_3}{dt^2}$ is the added mass as a function of position in terms of h in Figure 50. Alternatively, default AquaSim values can be used.

$A_{33}\frac{dw}{dt}$ is the diffraction force.

The terms and the load formulation correspond to the load formulation using Morisons equation. This is seen by rearranging the terms in Equation 108. We denote $\frac{dA_{33}}{dh} = DL\frac{\rho}{2}Cd_{slam}$, where D can be seen as a reference diameter of the object and L a reference length:

$$F_3 = (\rho\Omega(t) + A_{33})\frac{dw}{dt} + DL\frac{\rho}{2}Cd_{slam}(v_{rel})^2 - A_{33}\frac{d^2\eta_3}{dt^2} + \rho g\Omega(t)$$

Equation 109

A_{33} can be given in terms of an added mass coefficient C_a . Multiplied with the submerged volume will give the added mass. As seen by Equation 108, AquaSim needs input in terms of added mass A_{33} , or the coefficient C_a given as a function of h (as shown in Figure 50) to account properly for these load terms in the water entry phase. AquaSim has default values for a circular- and rectangular cross section that can be used.

Generalizing to all degrees of freedom

Consider a beam divided into elements, as shown in Figure 51. Each element has a local coordinate system where the local x-coordinate is defined as going from node 1 to node 2 of the element, and the local z-axis is given as input.

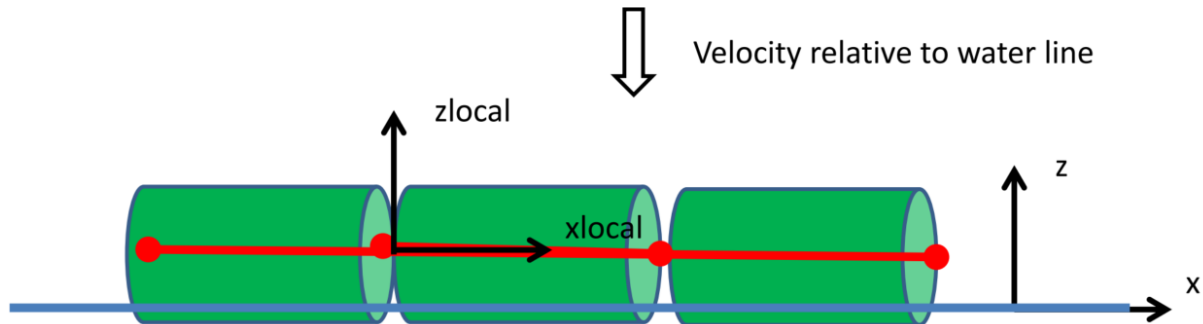

Figure 51 Beam divided into elements. Beam has visually been sliced; this can be interpreted as two-dimensional strips. In addition, a strip is introduced at the middle of the element

Strip theory is used to describe the analysis model entering the water. Each element is divided into two parts and treated separately. Consider the case as seen in Figure 51 where the local and the global z-axis have the same direction. Let u , v and w be the fluid velocity in the x-, y- and z-axis respectively. The terms in Equation 108 are interpreted as:

- The Froude-Kriloff force in the y- and z-direction is derived as $\rho\Omega(t)\frac{dv}{dt}$ and $\rho\Omega(t)\frac{dw}{dt}$ for the y- and z-axis respectively. $\Omega(t)$ is the submerged volume at the given time instant.
- The hydrostatic force $\rho g\Omega(t)$ is for any case pointing in the positive z-axis in the global coordinate system.
- $\frac{dA_{33}}{dh}(v_{rel})^2$ is the slamming force. Further details are described in chapter The ‘drag’ term in Morison equation.
- Added mass is added to the mass of the object as a function of displacement of the strip, both horizontally and vertically, A_{22} and A_{33} respectively. Added mass as a function of position in terms of h in Figure 50 should be given as input. This yields for A_{22} and A_{33} . Alternatively, default AquaSim values can be applied.
- The diffraction force horizontally and vertically is added to the Froude-Kriloff as $A_{22}\frac{du}{dt}$ $A_{33}\frac{dw}{dt}$ respectively, where A_{22} and A_{33} is the added mass at the given submergence.

In general, the object may approach the water surface in a skewed manner, as shown in Figure 52. Then, numerical integration must be used to derive the submerged volume for calculation of hydrostatic force and Froude-Kriloff. Added mass and diffraction is calculated based on the added mass for the actual submergence at each strip with interpolation between strips.

How the load term proportional to relative velocity squared is treated is described in chapter The ‘drag’ term in Morison equation.

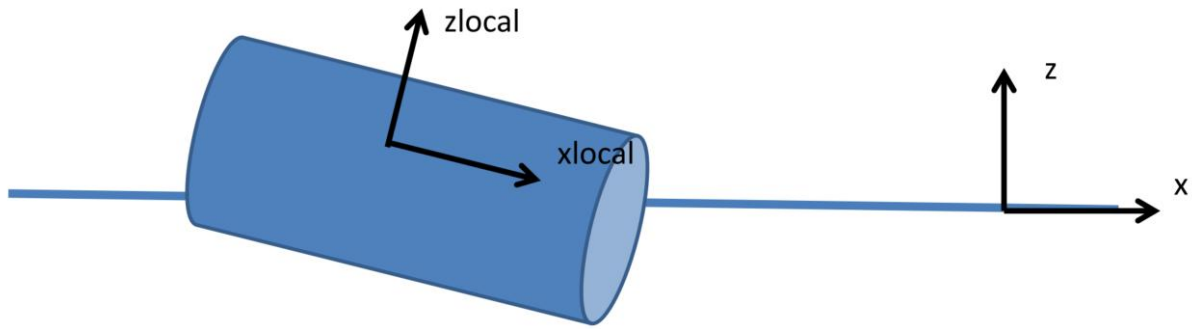

Figure 52 Object entering the water surface in a skewed manner

The ‘drag’ term in Morison equation

Consider the Morison equation in the case of force in the z- (3) direction (see e.g. (Faltinsen, 1990)):

$$F_3 = \frac{\rho_w C d_z Diam_N L_0}{2} (u_3 - \dot{\eta}_3) \sqrt{(u_2 - \dot{\eta}_2)^2 (u_3 - \dot{\eta}_3)^2} + \frac{\rho_w C m_z Diam_z^2 L_0 \pi}{4} a_3 - \frac{\rho_w (C m_z - 1) Diam_z^2 L_0 \pi}{4} \ddot{v}_{3m}$$

Equation 110

for a circular cylinder. In Equation 110, there is only forces in the local y- and z-direction according to the cross-flow principle. $Diam_N$ is a relevant diameter of the object, calculated in the direction of the flow based on $Diam_y$ and $Diam_z$. $Cm = Ca + 1$. The load term of Equation 110 (which is proportional to the relative velocity squared) is given in Equation 111:

$$F_3 = \frac{\rho_w C d_z Diam_N L_0}{2} (u_3 - \dot{\eta}_3) \sqrt{(u_2 - \dot{\eta}_2)^2 (u_3 - \dot{\eta}_3)^2}$$

Equation 111

In the case of water entry, the cross-flow force, in the local z-direction, is calculated in the same way as in Equation 111:

$$F_3 = \frac{\rho_w C d_{slam} Diam_N L_0}{2} (w - \dot{\eta}_3) \sqrt{(v - \dot{\eta}_2)^2 (w - \dot{\eta}_3)^2}$$

Equation 112

$C d_{slam}$ can be derived from input based on the relation $\frac{dA_{33}}{dh} = DL \frac{\rho}{2} C d_{slam}$. At each strip, this value is derived, and values are interpolated between the strips. Also, forces in the local y-direction are calculated. The values for $C d_y$ in the water entry phase could be given as input, or by applying the default AquaSim-values. **Note (16).**

Note (16)

Slamming calculation is based on having the local z-axis pointing in a direction relevant for the slamming loads. This should be enabled by the user.

AquaSim default values

For a circular cross section, AquaSim provides default values for parameters relevant for slamming. They are based on values found in (Faltinsen, 1990), shown in Figure 53:

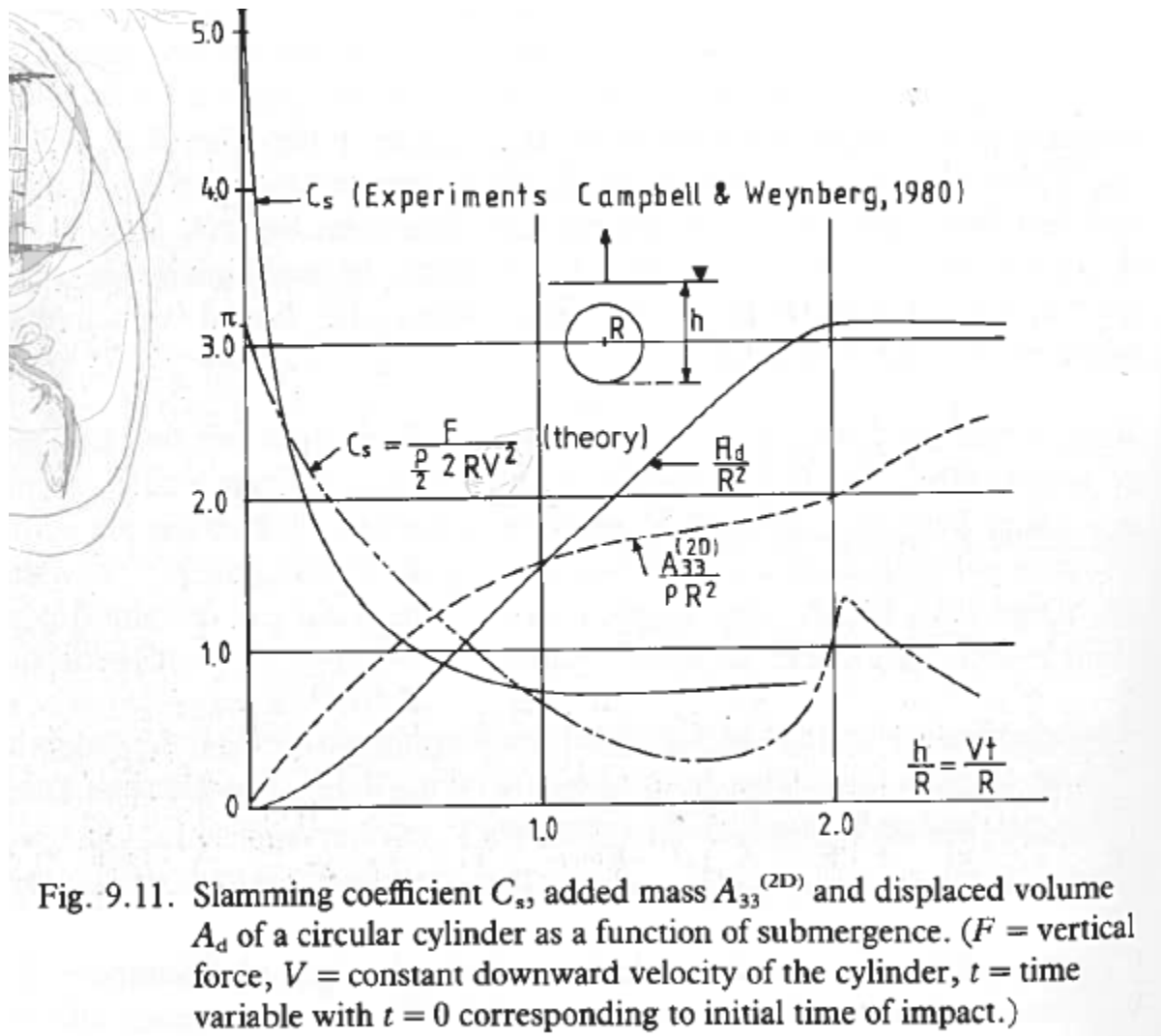

Figure 53 From Faltinsen (1990)

The AquaSim default values are compared to the two cases presented in Figure 53 (Faltinsen and Campbell & Weynberg). The results are shown in Figure 54.

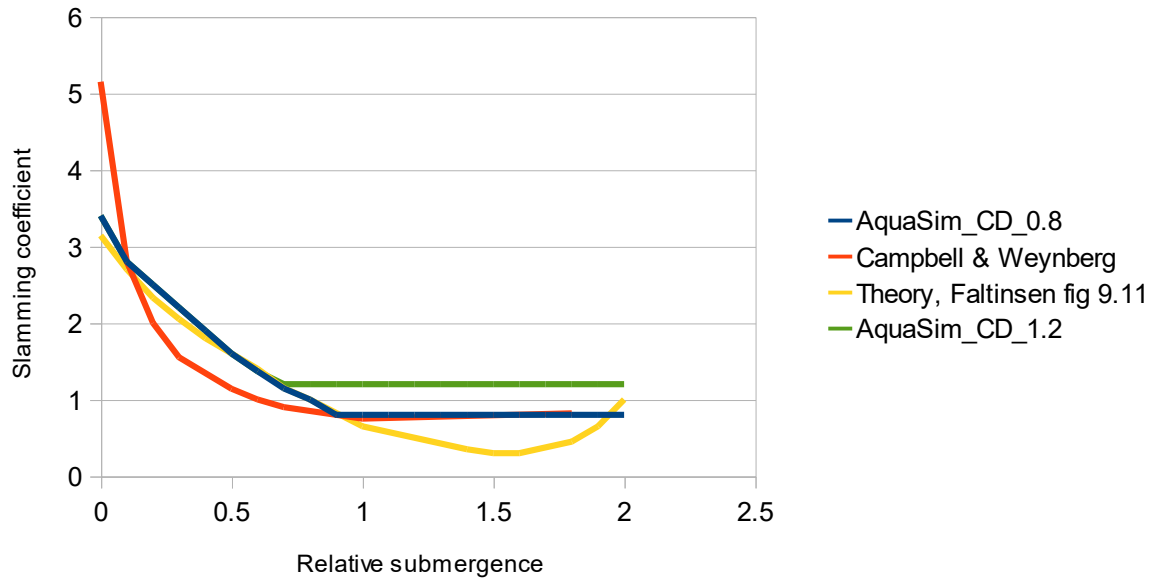

Figure 54 Comparison between AquaSim and Faltinsen and Campbell & Weynberg

In Figure 54, relative submergence is found on the horizontal axis. The value 2 means fully submergence (2*radius from top). Values for ‘AquaSim_CD_0.8’ is presented in Table 6.
Note (17).

Table 6 Results from AquaSim analysis

Submergence [-]	AquaSim_CD_0.8
0	3.4
0.1	2.8
0.2	2.5
0.3	2.2
0.4	1.9
0.5	1.6
0.6	1.368
0.7	1.144
0.8	1.0
0.9	0.8
1.0	0.8
1.1	0.8
1.2	0.8
1.3	0.8
1.4	0.8
1.5	0.8
1.6	0.8
1.7	0.8
1.8	0.8
1.9	0.8
2.0	0.8

Note (17)

Note that the values are found by linear interpolation of the data seen in Table 6. AquaSim chooses the highest value of slamming coefficient and drag coefficient.

The corresponding added mass values are the integral of the slamming coefficient. For a fully submerged added mass coefficient, the cross section is fully submerged. Alternatively, the user may apply a slamming coefficient in Table 6 and introduce added mass coefficient as a function of submergence.

10.20.2 Water exit

Water exit is defined as the case where the structure moves out of the water, whereas water entry is defined as the case where the submerged part of a strip is increasing. At relative velocity close to 0, values are interpolated between the water exit and water entry values. This is when $-0.1 \text{ m/s} < V_{rel} < 0.1 \text{ m/s}$. Water exit are calculated in the same manner as for water entry. The only difference is that values are used for $\frac{dA_{33}}{dh} = DL \frac{\rho}{2} C d_{slam}$. The values for A_{33} as a function of h for water exit may be given as input, or by applying AquaSim default values. **Note (18).**

Note (18)

Added mass in the local y-direction should also be given as input (if not using AquaSim default values).

10.21 Buckling analysis

AquaSim accounts for buckling in a normal analysis. This means that if the structure is unstable buckling-wise it will buckle in the analysis. For beams, one may extract the explicit buckling safety margin at any time step in the analysis.

10.22 Beam buckling

Explicit calculation of beam buckling is an add-on to AquaSim. It is reached through the Export-menu in AquaEdit. The buckling add-on solves the linearized eigenvalue problem:

$$K_{elem} - \delta K_{geom} = 0$$

Equation 113

at each timestep in the analysis. K_{elem} is the material stiffness for the structural configuration at the given timestep. K_{geom} is the geometrical stiffness in the structural configuration at the given timestep. The results found is the eigenvalue δ , which is the factor the load distributions should be linearly increased to, to obtain linearized buckling. The corresponding eigenvector is the buckling shape. Negative δ -values are disregarded in AquaSim, meaning the reversing load distributions are not considered.

The buckling calculation in AquaSim is a numerical calculation. A “shift” parameter may be applied, which is a presumed value in the close range of the eigen value. The parameter makes the numerical search for the eigen values go faster. Figure 55 shows the third buckling

shape for a vertical pole. Figure 56 shows the first buckling shape (meaning the buckling shape introduced by the lowest load) for a fish farm cage.

More information about beam buckling theory is found in (Aquastructures, 2014a).

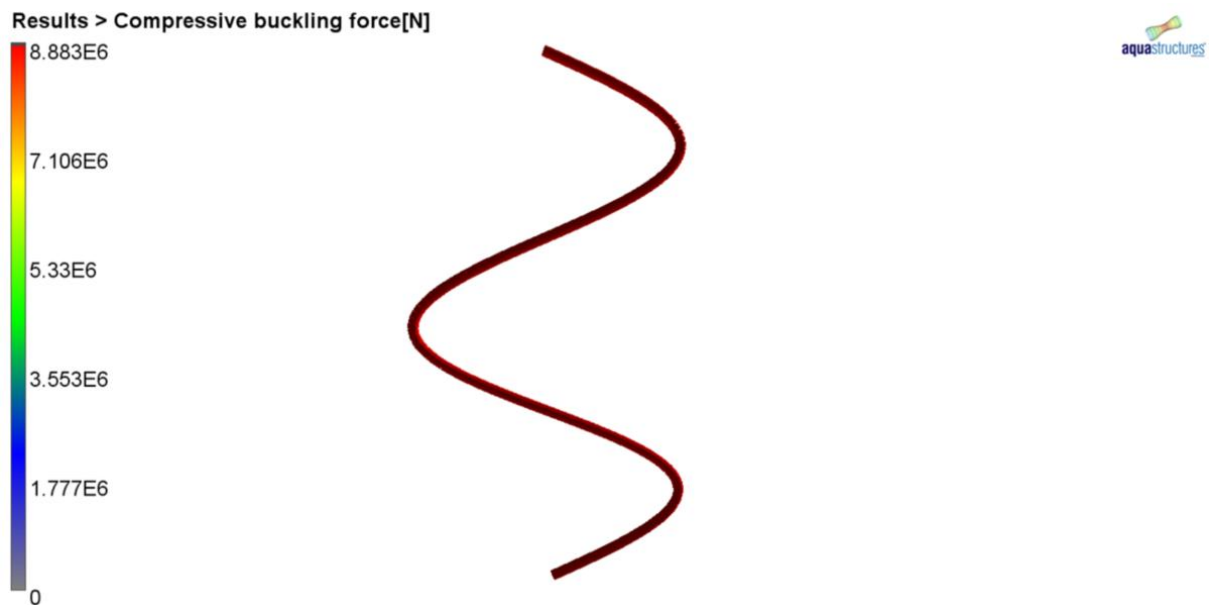

Figure 55 Calculation of buckling length and shape for a vertical beam with a node load on top

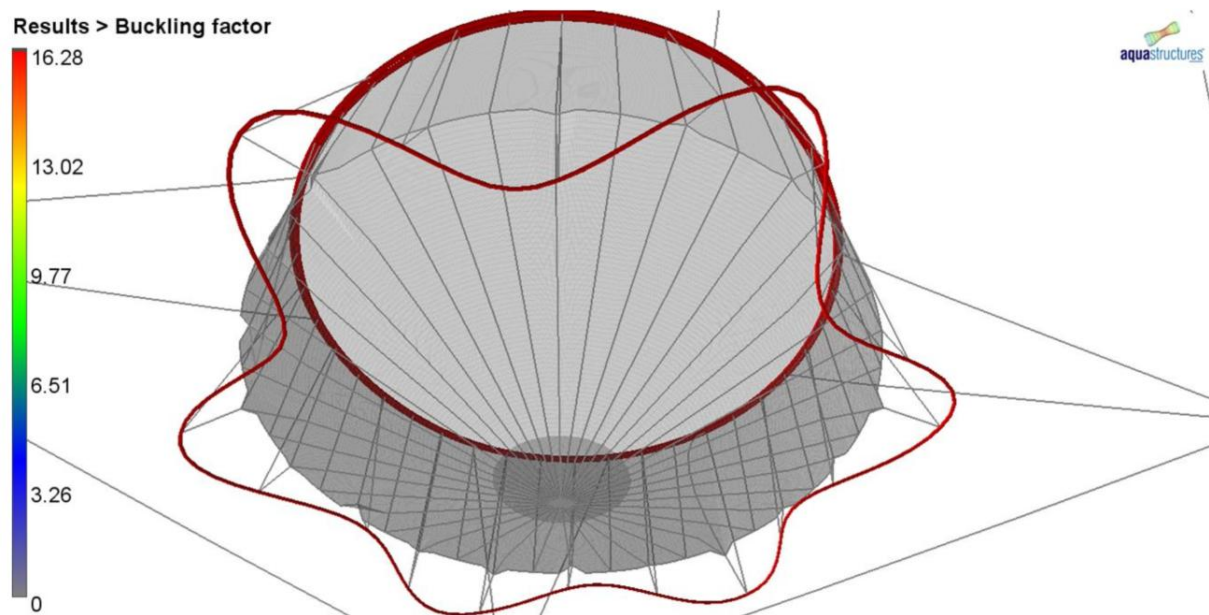

Figure 56 First buckling shape for a fish farm cage

10.23 Explicit eigenperiod analysis

Explicit calculation of eigenperiods is an add-on to AquaSim. It is reached through the Export-menu in AquaEdit. The add-on solves the linearized eigenvalue problem at each timestep:

$$K - \omega^2 M = 0$$

Equation 114

where K is the stiffness for the structural configuration at the given timestep, including geometrical and element stiffness. M is the mass of the structural configuration at the given timestep, including structural mass and added mass.

The results found is the eigenvalue $\lambda = \omega^2$, which is the eigen frequency. $T = 2\pi/\omega$ is the eigen period. The corresponding eigenvector is the eigenvector for the presented result.

A mooring line may have several eigenperiods, such that it might be of interest to derive the eigenperiods of a system not including eigenperiods in the mooring line. Hence, AquaSim have a possibility for omitting such eigenperiods.

11 COMPONENT CONTACT

The basic principle of establishing contact between elements in AquaSim is to first define contact between component groups in AquaEdit. Two-and-two component groups can be assigned contact. From this a Component contact-table is created which defines how the contact should take place.

Contact between elements in the component groups is based on a spring, as illustrated in the figure below. We have the following relation between force, spring stiffness and displacement:

$$F = k \cdot r^5$$

Equation 115

where F is the contact force, k is the spring stiffness and r is the relative distance between the elements. In addition, you can also assign friction, damping and distance when contact should start.

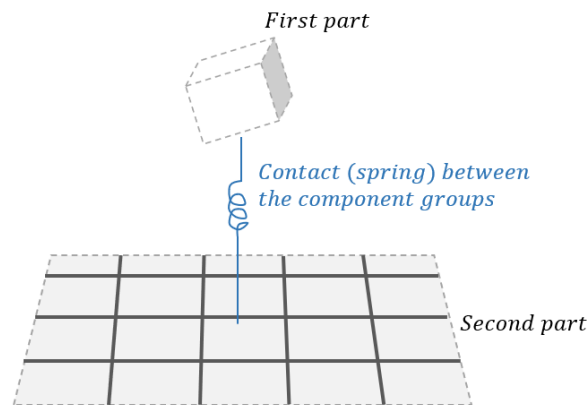

Figure 57

11.1 Component contact table

11.1.1 First part and Second part

To establish contact, you need to select a “First part” and a “Second part”. AquaSim will keep track of the position and distance between the “First part” and “Second part” in all timesteps in the analysis, this is illustrated in the figure below. If elements in “First part” gets closer to “Second part” than the specified values for where contact is assumed a force will push the elements apart.

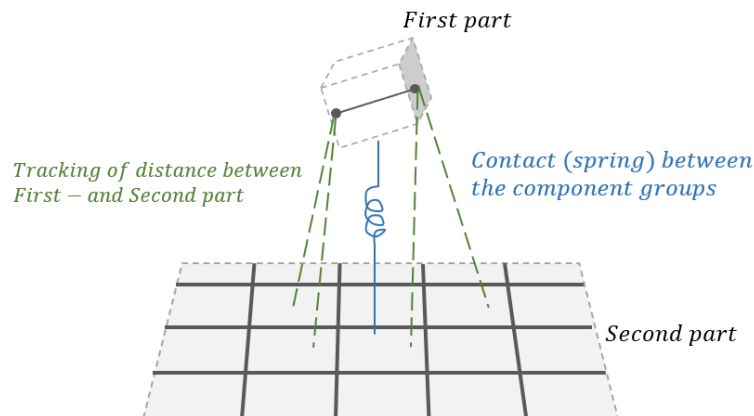

Figure 58

11.1.2 Distance / Radius

Distance / Radius defines when contact should occur. AquaSim treats this parameter different depending on the type of component type that is defined as ‘First part’ and ‘Second part’.

Contact between component type Beam and Membrane:

Then this can be interpreted as a distance. AquaSim will follow each node of elements in ‘First part’ at all timesteps, and for elements in ‘Second part’ the surfaces are tracked. If a node in ‘First part’ gets closer than the specified value, forces will push the elements apart. This principle applies also if contact is established between Truss and Membrane.

Contact between component type Beam and Beam:

Then this can be interpreted as a radius from ‘First part’ to ‘Second part’. When elements get closer than the specified value, forces will push the elements apart. This principle applies also if contact is established between Truss and Truss, or Beam and Truss.

11.1.3 Stiffness

Is the spring stiffness of the contact. The higher the stiffness, the tighter the contact.

11.1.4 Damping stiffness

Provides damping in the direction normal to the contact. This factor is proportional to Stiffness. If an impact is elastic, the element in ‘First part’ will bounce back and if the impact is plastic the energy of the impact will be drained, and the element in ‘First part’ will not bounce back.

11.1.5 Dynamic friction damping

This is a factor that is proportional to the stiffness in the tangential direction to the element. This can be interpreted as friction that prevents the elements in 'First part' from sliding back to the impact point. The factor is dependent on the relative velocity between the colliding elements. It works in the dynamic steps of the analysis.

11.1.6 Static stiffness friction coefficient

Is a friction force coefficient that is proportional to the relative displacement between the colliding elements. This coefficient is constant and pulls the object back to the impact point.

11.1.7 Max initial distance

When establishing contact between two component groups, AquaSim will keep track of the position and relative distance between all elements in the two component groups. If you have a model with large number of elements, this may contribute to slow down analysis time. Applying Max initial distance will only establish contact between elements that have an initial distance that is less than this value. If Max initial distance is 0, then contact will be established for all elements in the two component groups.

12 REFERENCES

- Aquastructures. (2014a). *Beam buckling and eigenperiods in AquaSim*. Tech. rep. TR-FOU-1122-6.
- Aquastructures. (2016). *Nets with bending resistance in AquaSim*. Tech. rep. TR-FOU-2222-5.
- AquaStructures. (2019a). *Water entry and exit*. Tech. rep. TR-FOU-1984-3.
- Aquastructures. (2019b). *AquaSim, Irregular wave calculation and validation*. TR-FOU-2161-1.
- Aquastructures. (2020a). *Manual for working directly in the AquaSim input file (Advanced use)*. FOU-2020-2600.
- Aquastructures. (2020b). *Shell elements in AquaSim, case studies for validation*. Tech. rep. TR-FOU-2328-2.
- Aquastructures. (2021a). *Spectral Windloads in AquaSim*. Tech. rep. TR-FOU-2328-4.
- Aquastructures. (2021b). *Sloshing in closed tanks*. Tech. rep. TR-FOU-2328-3.
- Aquastructures. (2021c). *Wave amplitude- and current reduction*. Tech. rep. TR-FOU-2328-10.
- Aquastructures. (2022a). *Cresting Wave Factor, Nonlinear wave kinematics in AquaSim*. Tech. rep. TR-FOU-2328-9.
- Aquastructures. (2022b). *Hexagon Net in AquaSim*. Oslo: Tech. rep. TR-FOU-100004-1.
- Aquastructures. (2023). *Verification and benchmarking of AquaSim*. Techn. rep. TR-FOU-1755-1.
- Aquastructures. (2024b). *AquaEdit User Manual, 2.20*. TR-20000-583-1.
- Aquastructures. (2024c). *Current reduction in AquaSim*. Tech. rep. TR-FOU-2500-1 Revision no. 2.
- Aquastructures. (2024d). *Drag coefficient for net panels*. Tech. rep. TR-FOU-100004-6 Revision no. 2.
- Aquastructures. (2024g). *Parameters impermeable net*. TR-FOU-100004-7, Revision no. 1.
- Aquastructures. (2025a). *Loads on Impermeable Nets and Large Volume Objects in AquaSim*. Techn. rep. TR-FOU-2328-6. Rev9.
- Aquastructures. (2025b). *Lice skirt and Closed compartment - Impermeable properties in AquaSim*. TN-FOU-100004-7.
- Aquastructures. (2025c). *Surface tarpaulin - Impermeable properties in AquaSim*. TN-FOU-101830-6.
- Aquastructures. (2025d). *Surface tarpaulin - Load formulation in AquaSim*. TR-FOU-100004-4.

- Aquastructures. (2025e). *Morison free plate load formulation to shell and membrane elements*. Tech. rep. TR-FOU-2328-8 Revision no. 4.
- Aquastructures. (2025f). *Regular net - Load formulation in AquaSim*. TR-FOU-100004-6_rev3.
- Babarit, A., & Delhommeau, G. (2015). Theoretical and numerical aspects of the open source BEM solver NEMOH. *11th European Wave and Tidal Energy Conference (EWTEC2015)*.
- Balash, C., Colbourne, B., Bose, N., & Raman-Nair, W. (2009). Aquaculture Net Drag Force and Added Mass. *Aquacultural Engineering*. Vol. 41(1), pp. 14-21.
- Barkley, D. (2006). Linear analysis of the cylinder wake mean flow. *Europhysics Letters*. Vol. 75(5), pp. 750-756.
- Bell, K. (1987). *Matrisestatikk*. Tapir. ISBN 82-519-0803-5.
- Bergan, P., & Felippa, C. (1985). A triangular membrane element with rotational degrees of freedom. *Computer Methods in Applied Mechanics and Engineering*. Vol. 50(1), pp. 25-69.
- Bergan, P., Larsen, P., & Mollestad, E. (1982). *Svigning av konstruksjoner*. Tapir. ISBN 82-519-0706-3.
- Berstad, A. (1999). *Calculation of fatigue damage in ship structures*. Ph.D. Thesis. Trondheim, Norway: Faculty of Marine Technology, Norwegian University of Science and Technology.
- Berstad, A. (2025). Drag Loads to Aquaculture Nets and the Corresponding Flow Velocity Reduction Behind. *XI International Conference on Computational Methods in Marine Engineering*.
- Berstad, A. J., & Grøn, P. (2023). Model basin testing of a floating solar system compared to analysis for establishment of design verification culture. *X International Conference on Computational Methods in Marine Engineering. MARINE2023*.
- Berstad, A., & Heimstad, L. (2015). Numerical formulation of sealoads to impermeable nets. *VI International Conference on Computational Methods in Marine Engineering. MARINE2015*, pp. 339-352.
- Berstad, A., & Heimstad, L. (2017). Experience from introduction of the design code NS 9415 to the aquaculture industry in Norway and expanding the scope to cover also operations. *International Conference on Ocean, Offshore and Arctic Engineering. OMAE2017-62426*. Vol. 9.
- Berstad, A., & Tronstad, H. (2005a). Response from current and regular/irregular waves on a typical polyethylene fish farm. *Proceedings from Maritime Transportation and Exploitation of Ocean and coastal Resources (IMAM)*.
- Berstad, A., & Tronstad, H. (2007). Development and Design Verification of a Floating Tidal Power Unit. *26th International Conference on Offshore Mechanics and Arctic Engineering. OMAE2007-29052*. Vol. 5, pp. 417-424.

- Berstad, A., & Tronstad, H. (2008). Use of Hydroelastic Analysis for Verification of Towed Equipment for Acquisition of Seismic Data. *27th International Conference on Offshore Mechanics and Arctic Engineering. OMAE2008-57850. Vol. 4*, pp. 631-636.
- Berstad, A., Trondstad, H., & Ytterland, A. (2004). Design Rules for Marine Fish Farms in Norway: Calculation of the Structural Response of Such Flexible Structures to Verify Structural Integrity. *Proceedings of 23rd International Conference on Offshore Mechanics and Arctic Engineering. OMAE2004-51577. Vol. 3*, pp. 867-874.
- Berstad, A., Tronstad, H., Sivertsen, S.-A., & Leite, E. (2005b). Enhancement of Design Criteria for Fish Farm Facilities Including Operations. *24th International Conference on Offshore Mechanics and Arctic Engineering. OMAE2005-6751. Vol. 2*, pp. 825-832.
- Berstad, A., Walaunet, J., & Heimstad, L. (2012). Loads From Currents and Waves on Net Structures. *31th International Conference on Offshore and Arctic Engineering. OMAE2012-83757. Vol. 7*, pp. 95-104.
- Blevins, R. (1984). *Applied Fluid Dynamics Handbook*. Van Nostrand Reinhold Co.
- Catenary Calculator*. (2021, 08 10). Retrieved from ABC Moorings: <http://abc-moorings.weebly.com/catenary-calculator.html>
- Darcy, H. (1856). *Les fontaines publiques de la ville de Dijon: exposition application*. Paris: Victor Dalmont.
- Eggen, T. (2000). *Buckling and geometrical nonlinear beam-type analyses of timber structures. Ph.D. Thesis*. Trondheim, Norway: Department of Structural Engineering, Norwegian University of Science and Technology.
- Faltinsen, O. (1990). *Sea Loads on Ships and Offshore Structures*. Cambridge University Press. ISBN 0-521-37285-2.
- Fathi, D. (1996). *ShipX Vessel Responses (Veres) User's Manual*. Trondheim, Norway: Norwegian Marine Technology Research Institute (MARINTEK).
- Fredheim, A. (2005). *Current forces on net structure. Ph.D. Thesis*. Trondheim, Norway: Faculty of Engineering Science, Norwegian University of Science and Technology.
- Goldstein, S. (1938). *Modern Development in Fluid Dynamics. Vol. 2*. Oxford: Clarendon Press.
- Goldstein, S. (1965). *Modern Developments in Fluid Dynamics. Vol. 1*. Oxford: Clarendon Press.
- Halse, K. (1997). *On vortex shedding and prediction of vortex-induced vibrations of circular cylinders. Ph.D. Thesis*. Trondheim, Norway: Department of Marine Structures, Norwegian University of Science and Technology.
- Haugen, B. (1994). *Buckling and stability problems for thin shell structures using high performance finite elements. Ph.D. Thesis*. University of Colorado, USA.
- Kristiansen, & Faltinsen, O. (2011). Current loads on aquaculture net cages. Unpublished paper and oral conversation. Autumn 2011. (A. Berstad, Interviewer)

- Lader, P., Dempster, T., Fredheim, A., & Jensen, Ø. (2008). Current induced net deformations in full-scale sea-cage for Atlantic Salmon (*Salmo salar*). *Aquacultural Engineering*. Vol. 38(1), pp. 52-65.
- Lader, P., Moe, H., Jensen, Ø., & Lien, E. (2009). *Nøter med høy soliditet - modellforsk.* Sintef Fiskeri og Havbruk AS. Tech. rep. SFH80 ISBN 9788-82-14-04946-6.
- Lader, P., Olsen, A., Jensen, A., Sveen, J., Fredheim, A., & Enerhaug, B. (2007). Experimental investigation of the interaction between waves and net structures - Damping mechanism. *Aquacultural Engineering*. Vol. 37(2), pp. 100-114.
- Langen, I., & Sigbjörnsson, R. (1979). *Dynamisk analyse av konstruksjoner*. Trondheim, Norway: Tapir. ISBN 82-519-0362-9.
- Løland, G. (1991). *Current Force On and Flow Thourgh Fish Farms*. Ph.D. Thesis. Trondheim, Norway: Division of Marine Hydrodynamics, Norwegian University of Science and Technology.
- Løland, G. (1993). Current forces on, and water flow through and around, floating fish farms. *Aquaculture International*. 1, pp. 72-89.
- MacCamy, R., & Fuchs, R. (1954). *Wave forces on piles: A diffraction theory*. Tech. Memo No. 69. U.S. Army Corps of Engineers. University of California.
- Molin, B. (2011). Hydrodynamic modeling of perforated structures. *Applied Ocean Reserach*. Vol. 33(1), pp. 1-11.
- Morison, J., Johnson, J., & Schaaf, S. (1950). The Force Exerted by Surface Waves on Piles. *Journal of Petroleum Technology*. Vol. 2(5), pp. 149-154.
- Newmark, N. (1959). A Method of Comutation for Structural Dynamics. *Journal of the Engineering Mechanics Division*. Vol. 85(3), pp. 67-94.
- Norwegian Standard. (2009). *NS9415 Marine Fish Farms - Requirements for site survey, risk analyses, design, dimensioning, production, installation and operation*. Lysaker: Standard Norge.
- Parisella, G., & Gourlay, T. (2016). *Comparison of open-source code Nemoh with Wamit for cargo ship motions in shallow water*. Centre for Marine Science and Technology (NTNU), Curtin University. Tech. Rep. 2016-23.
- Princeton. (2021). *Drag of Blunt Bodies and Streamlined Bodies*. Retrieved from https://www.princeton.edu/~asmits/Bicycle_web/blunt.html
- Tsukrov, I., Drach, A., DeCew, J., Swift, M., & Celikkol, B. (2011). Characterization of geometry and normal drag coefficients of copper nets. *Ocean Engineering*. Vol. 38(17-18), pp. 1979-1988.
- Tsukrov, I., Eroshkin, O., Fredriksson, D., Swift, M., & Celikkol, B. (2003). Finite element modeling og net panels using a consistent net element. *Ocean Engineering*. Vol. 30(2), pp. 251-270.
- Wikipedia. (2020a, 12 15). *Finite Element Method*. Retrieved from Wikipedia: https://en.wikipedia.org/wiki/Finite_element_method

Wikipedia. (2020b, 12 11). *Poisson's ratio*. Hentet fra Wikipedia:
https://en.wikipedia.org/wiki/Poisson%27s_ratio

Wikipedia. (2020c, 06 08). *Metacentric height*. Retrieved from Wikipedia:
https://en.wikipedia.org/wiki/Metacentric_height

Wikipedia. (2020d, 12 31). *Moody chart*. Retrieved from Wikipedia:
https://en.wikipedia.org/wiki/Moody_chart

Wikipedia. (2024c, 02 07). *Drag (physics)*. Retrieved from Wikipedia:
[https://en.wikipedia.org/wiki/Drag_\(physics\)](https://en.wikipedia.org/wiki/Drag_(physics))

13 APPENDIX A: VALIDATION OF THE AQUASIM SLAMMING FORMULATION

Two cases have been analyzed to validate the AquaSim slamming formulation. These are presented in the succeeding sections.

13.1 Case 1: Beam through water at constant velocity

This case is shown in Figure 59 and described in Table 7.

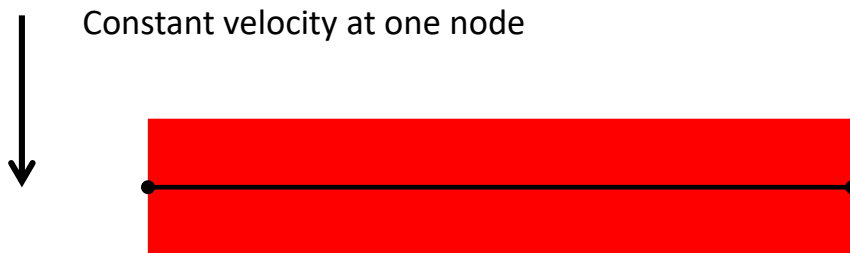

Figure 59 Horizontal beam moved at constant velocity through flat water line

Table 7 Case study 1, particulars

Circular beam	Values
Diameter	0.5 m
Beam length	10 m
Velocity	2 m/s
Drag diameter	0.5 -
Density beam	1025 kg/m ³

Results are presented in Figure 60, and shows that they compare well.

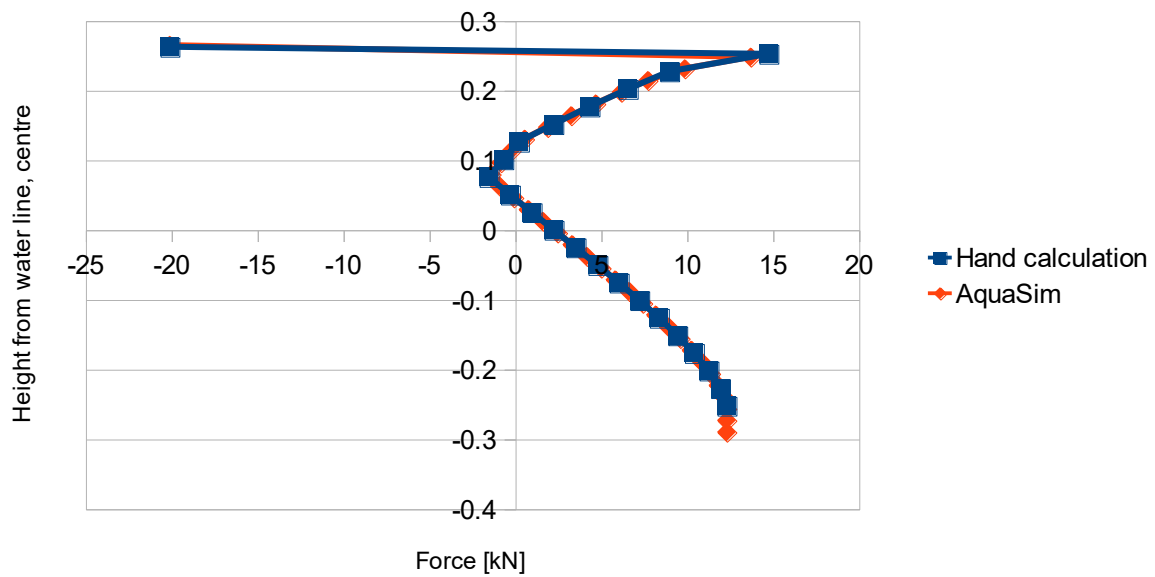

Figure 60 Comparison results, analytical formula and AquaSim analysis

13.2 Case 2: Fixed beam in waves

A beam is modelled in AquaSim and is kept still while a wave is applied to it directed in the local y-direction. The case is shown in Figure 61.

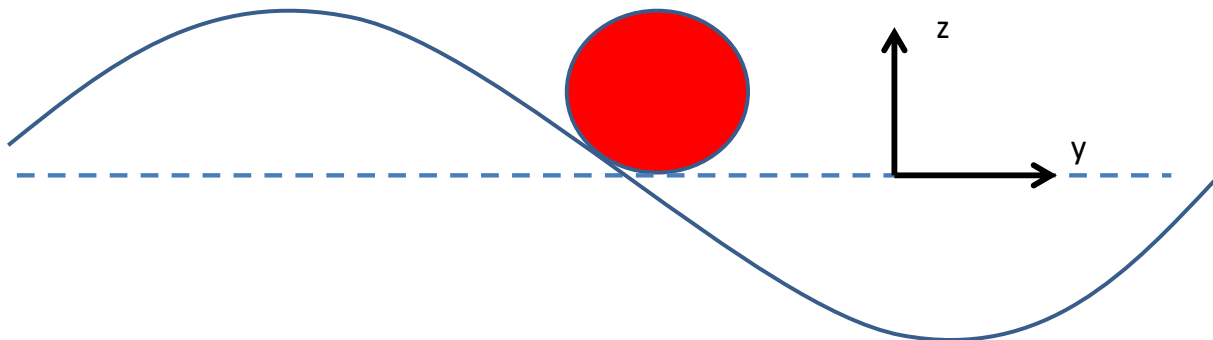

Figure 61 Fixed beam in waves

Results and comparison of analytical formula and AquaSim analysis is presented in Figure 62. The results compare well.

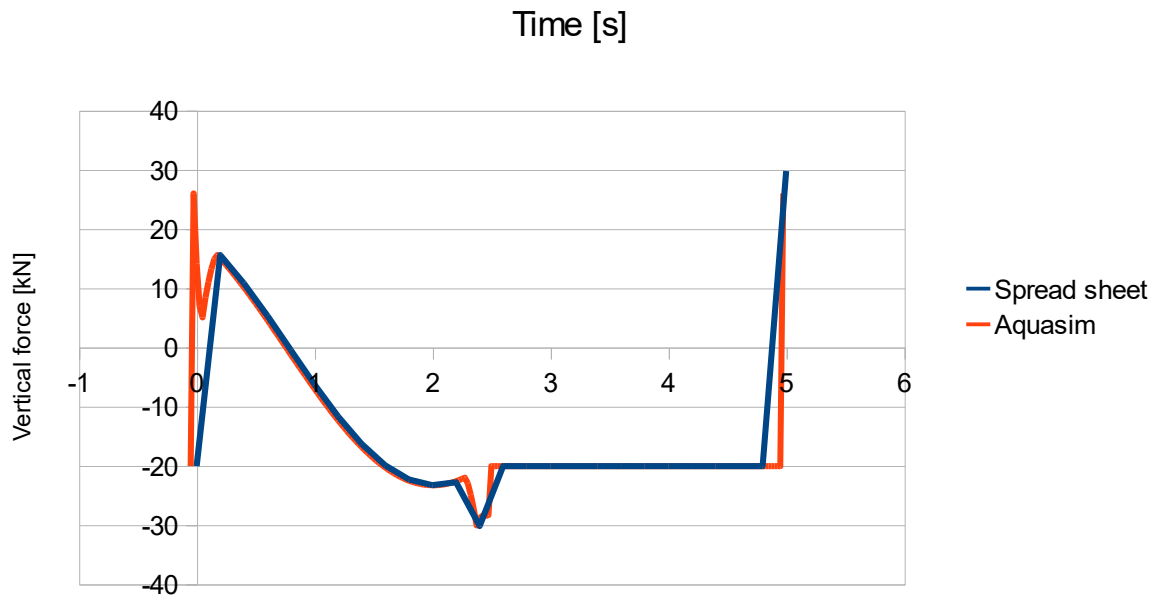

Figure 62 Comparison results, analytical formulae and AquaSim analysis